

INSTRUCTION MANUAL

SE017

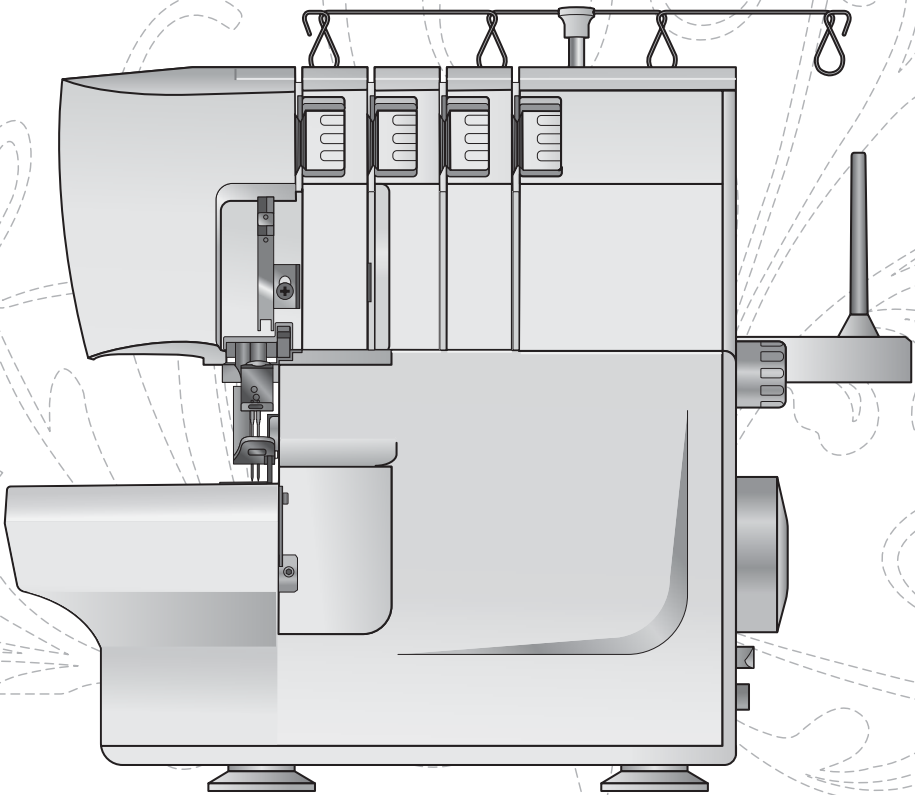

SINGER®

IMPORTANT SAFETY INSTRUCTIONS

When using an electrical appliance, basic safety precautions should always be followed, including the following:

Read all instructions before using this household sewing machine. Keep the instructions at a suitable place close to the machine. Make sure to hand them over if the machine is given to a third party.

This appliance can be used by children aged from 8 years and above and persons with reduced physical, sensory or mental capabilities or lack of experience and knowledge if they have been given supervision or instruction concerning use of the appliance in a safe way and understand the hazards involved. Children shall not play with the appliance. Cleaning and user maintenance shall not be made by children without supervision.

DANGER - TO REDUCE THE RISK OF ELECTRIC SHOCK:

A sewing machine should never be left unattended when plugged in. The electrical socket, to which the machine is plugged in should be easily accessible. Always unplug this sewing machine from the electric outlet immediately after using and before cleaning, removing covers, lubricating or when making any other user servicing adjustments mentioned in the instruction manual.

WARNING - TO REDUCE THE RISK OF BURNS, FIRE, ELECTRIC SHOCK, OR INJURY TO PERSON:

- Do not allow to be used as a toy. Close attention is necessary when this sewing machine is used by or near children.
- Use this sewing machine only for its intended use as described in this manual. Use only attachments recommended by the manufacturer as contained in this manual.
- Never operate this sewing machine if it has a damaged cord or plug, if it is not working properly, if it has been dropped or damaged, or dropped into water. Return the sewing machine to the nearest authorized dealer or service center for examination, repair, electrical or mechanical adjustment.
- Never operate the sewing machine with any air openings blocked. Keep ventilation openings of the sewing machine and foot control free from the accumulation of lint, dust, and loose cloth.
- Keep fingers away from all moving parts. Special care is required around the sewing machine needle.
- Always use the proper needle plate. The wrong plate can cause the needle to break.
- Do not use bent needles.
- Do not pull or push fabric while stitching. It may deflect the needle causing it to break.
- Wear safety glasses.

- Switch the sewing machine off (“0”) when making any adjustment in the needle area, such as threading needle, changing needle, threading bobbin, or changing presser foot, etc.
- Never drop or insert any object into any opening.
- Do not use outdoors.
- Do not operate where aerosol (spray) products are being used or where oxygen is being administered.
- To disconnect, turn all controls to the off (“0”) position, then remove plug from outlet.
- Do not unplug by pulling on cord. To unplug, grasp the plug, not the cord.
- The foot control is used to operate the machine. Never place other objects on the foot control.
- Do not use the machine if it is wet.
- If the LED lamp is damaged or broken, it must be replaced by the manufacturer or its service agent or a similarly qualified person, in order to avoid a hazard.
- If the cord connected with the foot control is damaged, it must be replaced by the manufacturer or its service agent or a similarly qualified person, in order to avoid a hazard.

For Overlock Machines only:

- Never operate without cutter cover or coverstitch table is securely installed.

SAVE THESE INSTRUCTIONS

Table of contents

Parts of the machine.....	5	Cleaning	21
Accessories	6	Oiling	21
Connecting the foot control and the power supply	6	Replacing the stationary cutter	22
Setting up the telescopic thread stand	7	Storage.....	22
Opening and closing the front cover.....	7	Servicing.....	22
Removing and replacing the flat bed extension.....	7	Trouble shooting.....	23
Presser foot lift.....	8	Stitch table.....	24
Changing the needles.....	8	Fabric / Needle / Thread table	28
Changing the presser foot	8	Specifications	28
Disengage the movable upper cutter.....	9		
Attaching the 2-thread overlock converter.....	9		
Threading the machine.....	10		
Threading the upper looper (purple).....	11		
Threading the lower looper (yellow)	12		
Threading the right needle (green).....	13		
Threading the left needle (blue).....	13		
Changing thread.....	14		
Start sewing.....	14		
Thread tension settings	15		
Differential feed adjustment.....	16		
Presser foot pressure adjustment.....	17		
Stitch width settings.....	17		
Stitch length settings	17		
Stitch finger lever setting	18		
Rolled edge sewing	18		
Flatlock sewing.....	19		
Corded overlock	20		
Pin placement.....	20		
Securing the thread chain.....	20		
Machine maintenance	21		

Parts of the machine

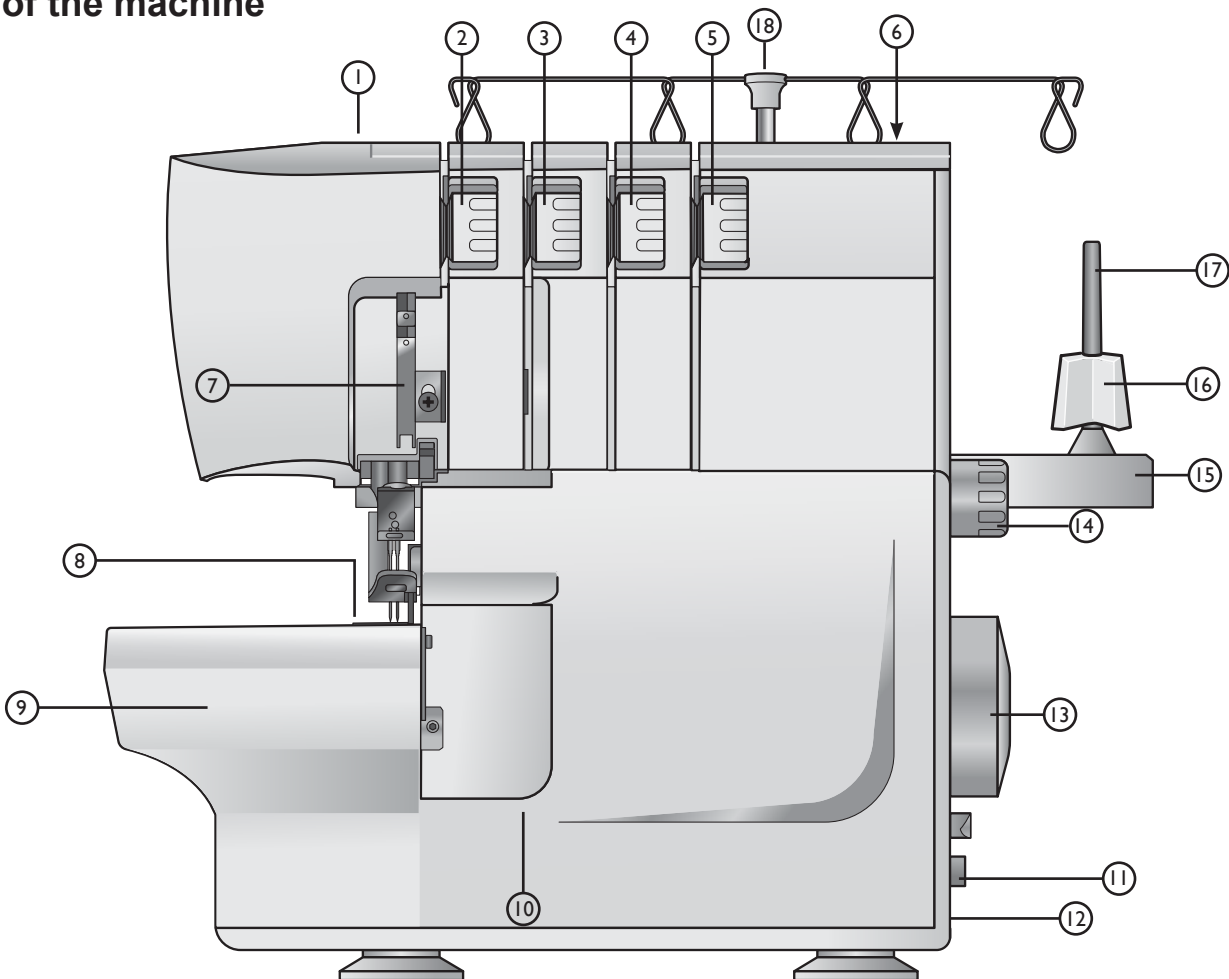

1. Presser foot pressure adjustment
2. Left needle thread tension dial (blue)
3. Right needle thread tension dial (green)
4. Upper looper thread tension dial (purple)
5. Lower looper thread tension dial (yellow)
6. Handle
7. Presser foot lifter
8. Stitch plate
9. Flat bed extension
10. Front cover
11. Differential feed adjusting lever
12. Power & light switch
13. Hand wheel
14. Stitch length dial
15. Spool stand
16. Cone holder
17. Spool pin
18. Telescopic thread stand

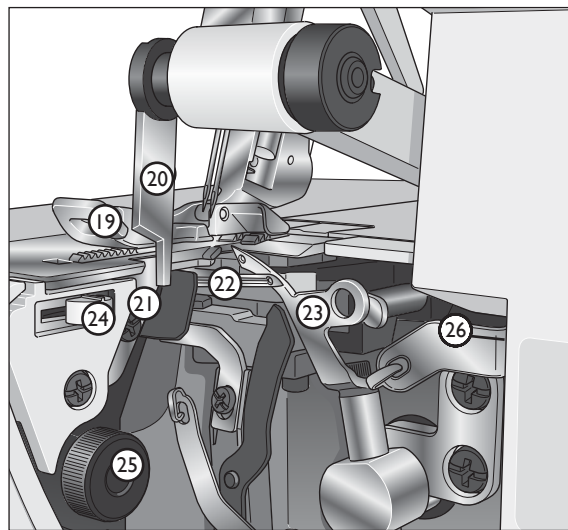

19. Presser foot
20. Movable upper cutter
21. Stationary lower cutter
22. Lower looper
23. Upper looper
24. Stitch finger lever
25. Seam width/cutting width adjustment knob
26. LED-light, (available on certain models)

Accessories

1. 2-thread converter
2. Needle pack including two needles, size #14/90. Two needles, size #14/90, are in the machine on delivery.
3. Screwdriver
4. Tweezers
5. Lint brush
6. Spare lower knife
7. Waste tray

Connecting the foot control and the power supply

Foot control to use with this machine:

- Type GTC/HKT 72C for 220-240V manufactured by DANYANG GUOTI MOTOR & APPLIANCE CO., LTD / ZHEJIANG HUAXING ELECTRIC MOTOR CO., LTD.

- Type GTE/HKT 7 for 100-120V manufactured by DANYANG GUOTI MOTOR & APPLIANCE CO., LTD / ZHEJIANG HUAXING ELECTRIC MOTOR CO., LTD.

Before plugging your machine in, make sure the voltage is the same as indicated on the plate under the machine. Specifications vary from country to country.

1. Connect the foot control/electric power cord to the socket on the machine.
2. Plug the power cord plug into the electric outlet.
3. Push the power switch to “-” to turn on the machine.
4. Press the foot control to start sewing. Use the foot control to adjust the sewing speed. The harder you press, the faster the machine will sew. To stop the machine from sewing, remove your foot from the control.
5. Push the power switch to “O” to turn off the machine.

Note: When the front cover is open the safety switch is activated and prevents the machine from sewing, even if the foot control is pressed.

Note: Your overlock machine is adjusted to provide the best stitch result at normal room temperature. Extreme hot and cold temperatures can affect the sewn result.

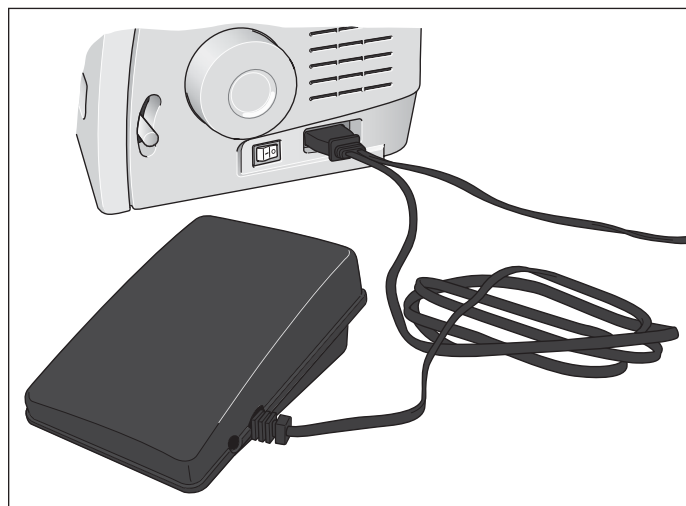
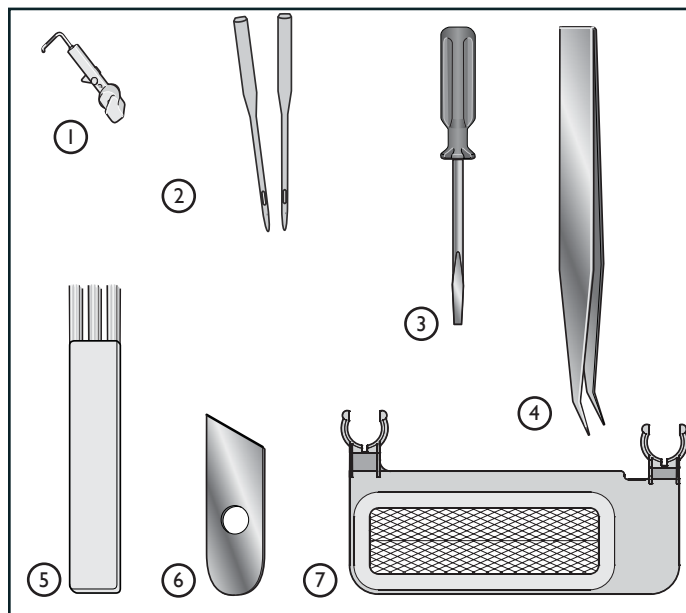

POLARIZED PLUG INFORMATION (FOR U.S.A. & CANADA ONLY)

This appliance has a polarized plug (one blade wider than the other). To reduce the risk of electric shock, this plug is intended to fit in a polarized outlet only way. If the plug does not fit fully in the outlet, reverse the plug. If it still does not fit, contact a qualified electrician to install the proper outlet. Do not modify the plug in any way.

Setting up the telescopic thread stand

Extend the telescopic thread stand to its full height, then turn until it clicks into place.

Place the thread spools or cones over the cone holders on the spool pin.

If the machine is already threaded, straighten the threads to prevent tangling.

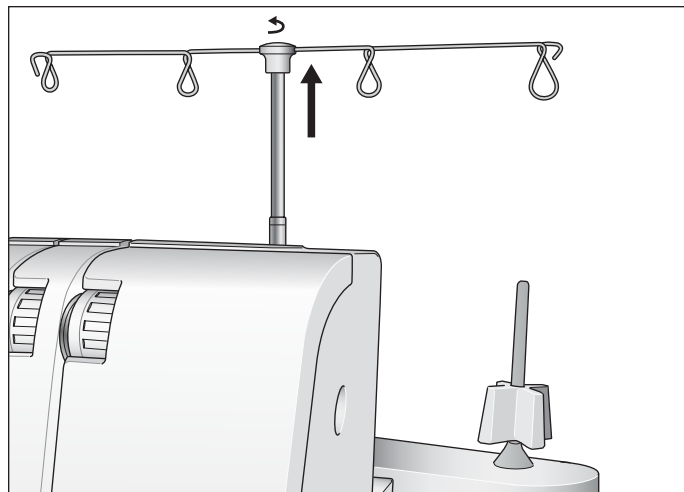

Opening and closing front cover

Open the front cover

First push the cover to the right as far as it will go and then pull it downward toward you.

Close the front cover

First pull the cover upward and then slide it to the left until it locks.

Note: The front cover has a safety switch and the machine will not sew if the front cover is open.

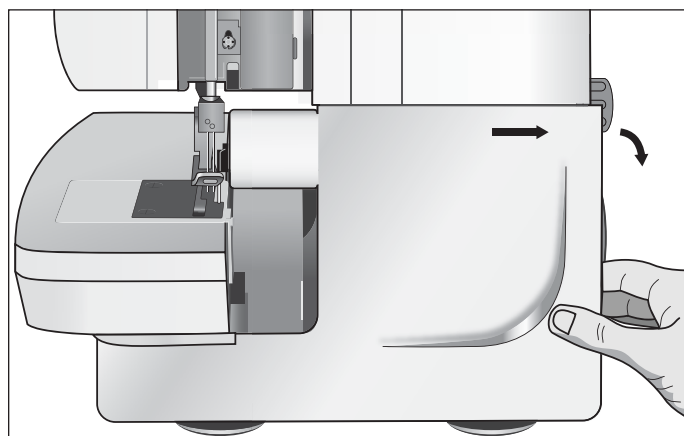

Removing and replacing the flat bed extension

Free arm sewing

For a free arm machine, slide off the flat bed extension. The free arm makes it easier to sew small items and hard to reach areas such as armholes and overcasting trouser cuffs.

To remove the flat bed extension

Slide the flat bed extension to the left and remove it from the machine.

To replace the flat bed extension

Align the projection on the flat bed extension with the groove on the back of the free arm and slide it to the right until it snaps into place.

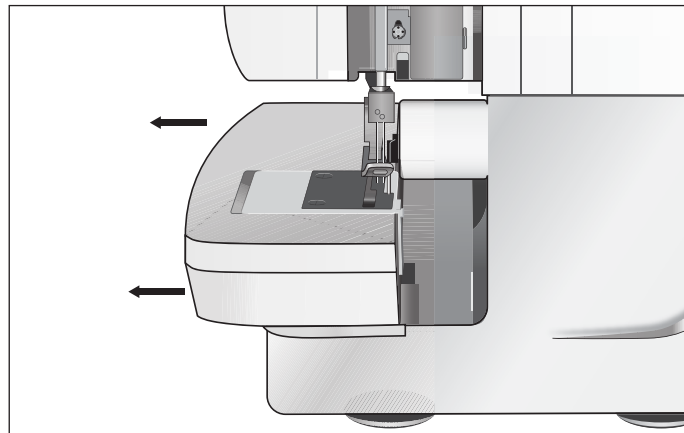

Presser foot lift

Raise the presser foot with the presser foot lift lever (A) at the back of the machine.

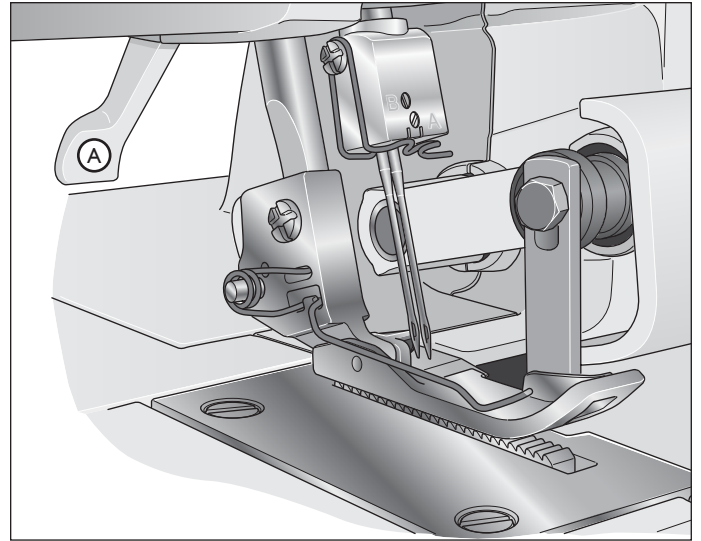

Changing the needles

 Turn off the main power switch and unplug the machine.

1. Turn the hand wheel toward you until the needles are at the highest position.
2. Loosen, but do not remove the left (B) and/or right (A) needle clamp screw with the small screwdriver while you are holding the needles.
3. Remove the left and/or right needle.
4. Hold the new needle/s with the flat surface to the back.
2. Insert the needle/s into the left and/or right needle clamp as far as it will go.
3. Securely tighten the left (B) and/or right (A) needle clamp screw.

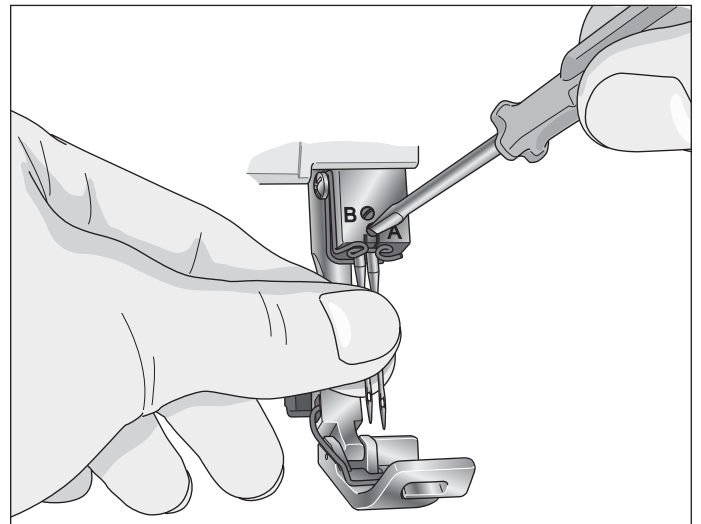

Changing the presser foot

 Turn off the main power switch and unplug the machine.

1. Raise the presser foot.
2. Turn the hand wheel toward you until the needles are in the highest position.
3. Push the white button on the back of the presser foot bar (A), and the foot will come off.
4. Place the new foot with the pin right underneath the groove of the ankle and lower the presser foot. Push the white button on the back of the presser foot bar (A) and the foot will snap into place.

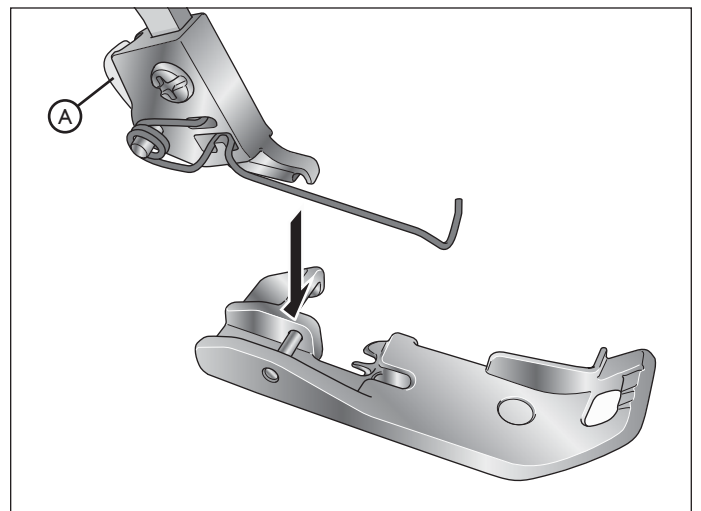

Disengage the movable upper cutter

Place the movable upper cutter in nonworking position

1. Turn the hand wheel toward you until the upper cutter is raised to the highest position.
2. Open the front cover.
3. Push the movable cutter holder to the right as far as it will go.
4. Turn the knob away from you until the cutter clicks into the nonworking horizontal position (A).

Note: If the cutter stops in the up position;

- Turn the hand wheel toward you until the cutter clears the top of the machine. Continue to rotate the cutter to the horizontal position.

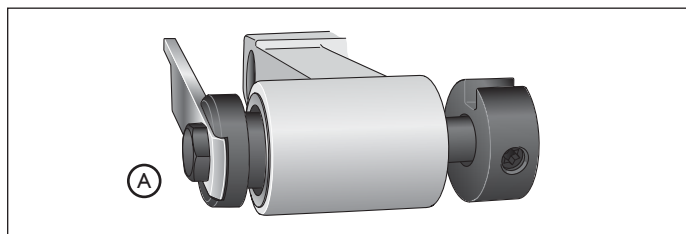
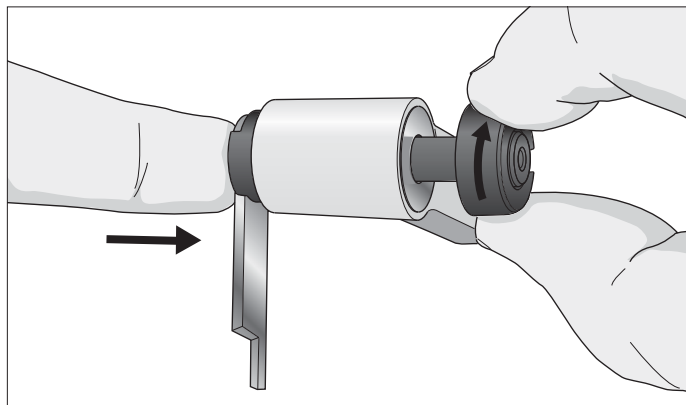

To place the movable upper cutter back in cutting position

1. Open the front cover and push the movable cutter holder to the right as far as it will go.
2. Turn the knob up and toward you until the cutter clicks into the cutting position.

Note: Always have the cutter down in the cutting position when sewing, because this machine must trim off any excess fabric to form the stitch over the fabric edge.

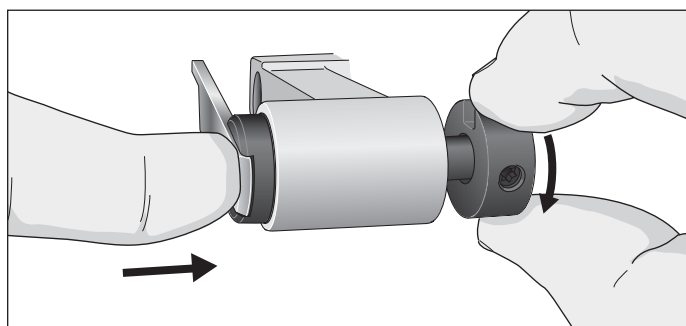

Attaching the 2-thread overlock converter

2-thread overlock stitches are sewn using one needle thread and the lower looper thread. Before sewing, the two-thread converter must be attached to the upper looper, so the machine will sew with only two threads.

1. Open the front cover.
2. Bring the upper looper to its lowest position by turning the handwheel toward you.
3. Insert the pin (A) of the converter in the hole (B) of the upper looper.
4. Put the positioning rib (C) in contact with the upper edge of the looper.
5. Insert the point (D) in the hole of the upper looper.

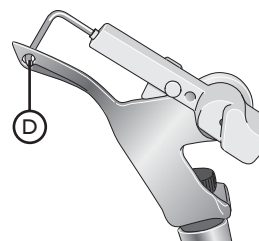
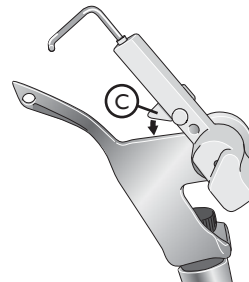
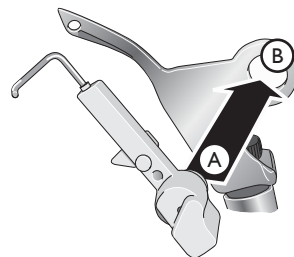

Removing the 2-thread overlock converter

1. Remove the point (D) from the hole of the upper looper and remove the converter.
2. Put the the 2-thread converter back to the accessory storage.

Threading the machine

A color coded diagram is located inside the front cover for quick reference.

When threading the machine, thread only in the following order:

1. Upper looper threading - Purple
2. Lower looper threading - Yellow
3. Right needle threading - Green
4. Left needle threading - Blue

Important:

If the lower looper should come unthreaded, do the following:

1. Unthread the needle(s)
2. Thread the lower looper
3. Thread the needle(s)

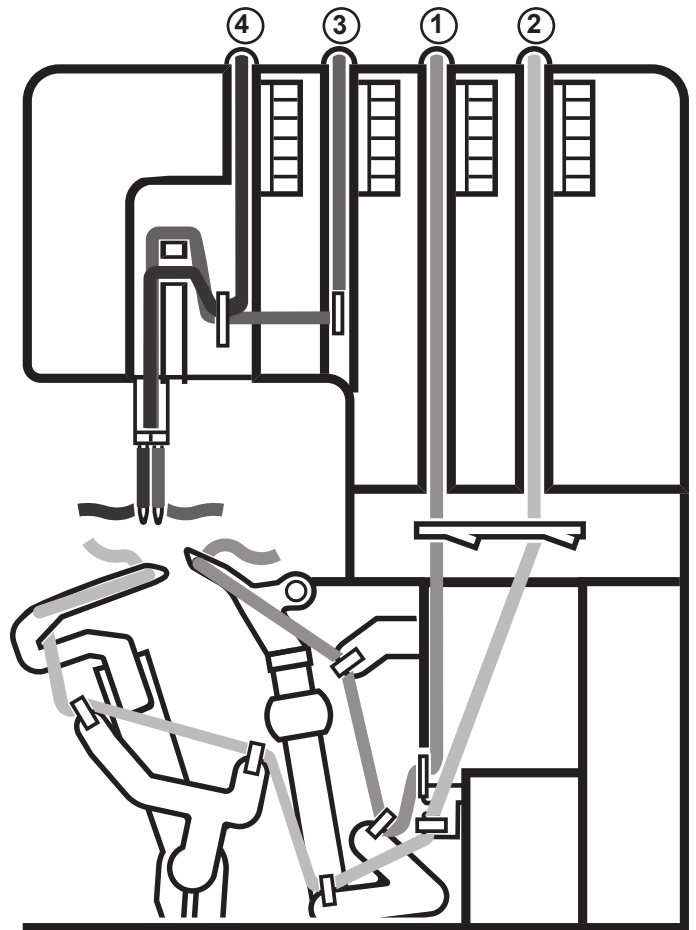

Threading the upper looper (purple)

1. Pass the thread from back to front through the thread guide on the thread stand (1).
2. Pull the thread from left to right under the thread guide at the back on the top cover (2). Use the tweezers to make the threading easier.
3. While holding the thread with both hands, pass it between the tension discs and pull it down to make certain it is properly placed between the tension discs (3).

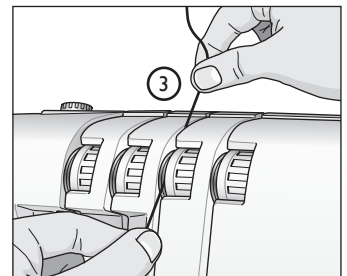
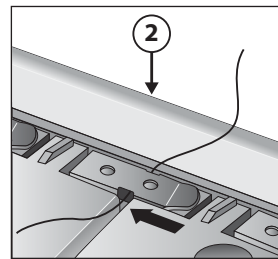
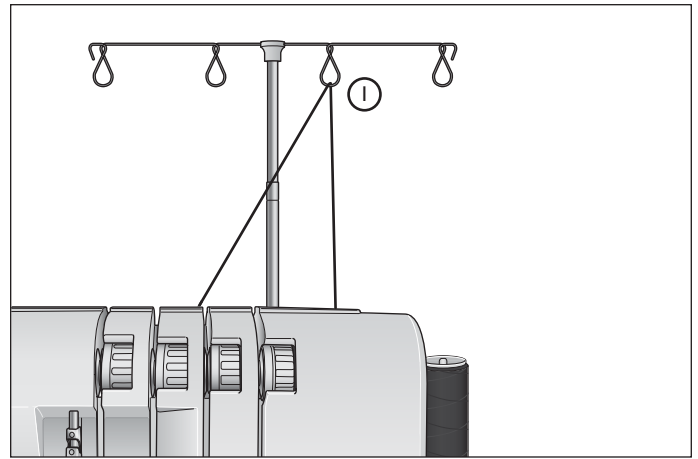

4. Thread the looper area of the machine following the purple color coded thread guides (4-7). Use the tweezers to make the threading easier.
5. Use the tweezers to bring the thread behind the lower looper and thread into the hole in the upper looper from front to back (8).
6. Pull about 10 cm of thread through the looper and place it to the back of the stitch plate.

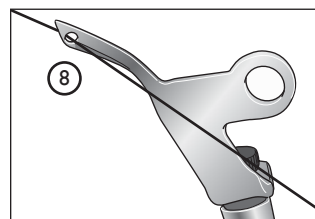
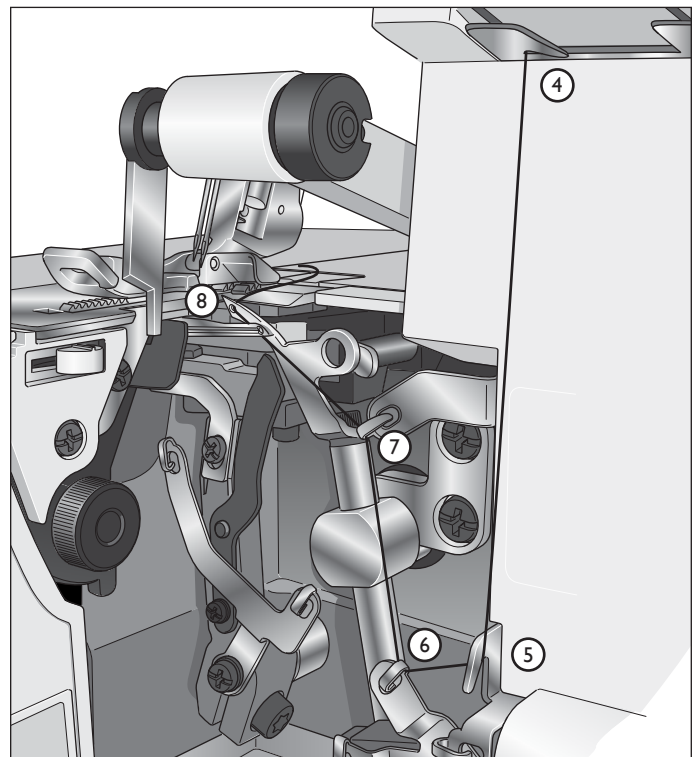

Threading the lower looper (yellow)

1. Pass the thread from back to front through the thread guide on the thread stand (1).
2. Pull the thread from left to right under the thread guide on the back of the top cover (2). Use the tweezers to make the threading easier.
3. While holding the thread with both hands, pass it between the tension discs and pull it down to make certain it is properly placed between the tension discs (3).
4. Turn the hand wheel toward you until the lower looper is at the far right.

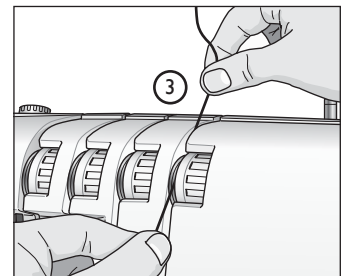
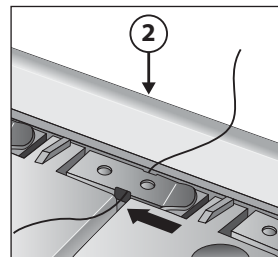
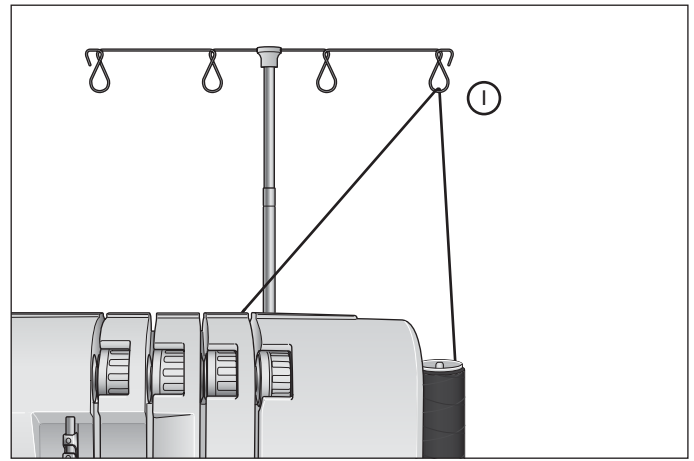

5. Thread the looper area of the machine following the yellow color coded thread guides (4-8). Use the tweezers to make the threading easier.
6. Pass the thread behind and over the tip of the lower looper (9A). Then pull it gently to the left until it will slip into the slot in the lower looper (9B).
7. Pick up the thread and pass it through the hole of the lower looper (10). The thread should be positioned in the groove of the lower looper.
8. Pull about 10 cm of thread through the looper and place it over the upper looper and to the back of the stitch plate.

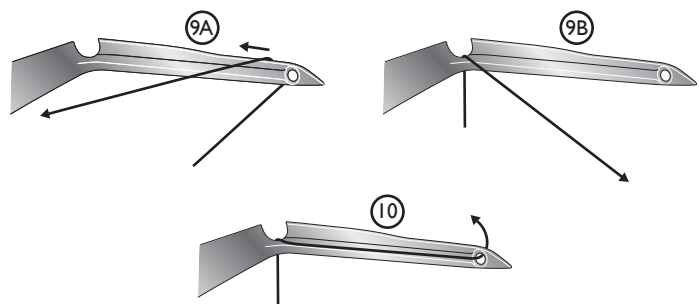
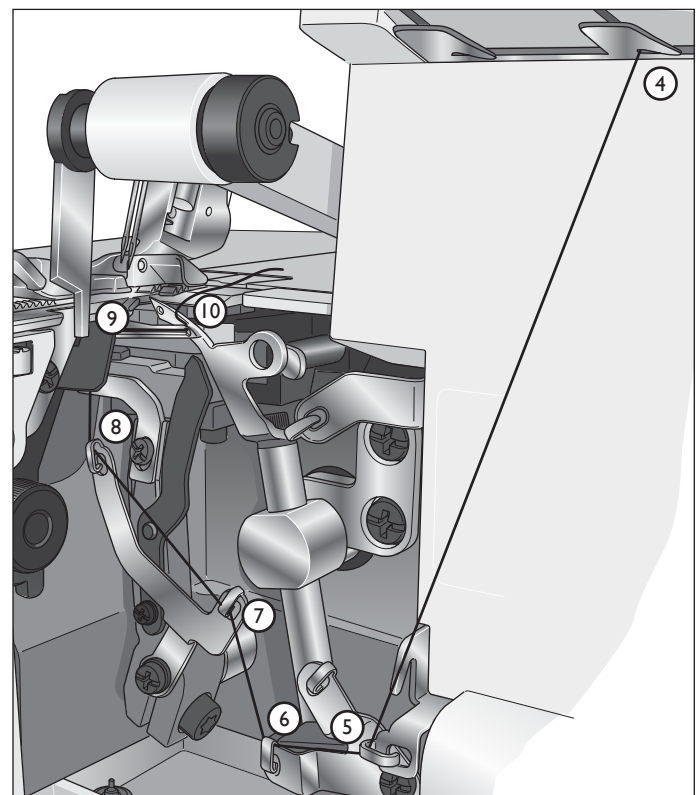

Threading the right needle (green)

1. Pass the thread from back to front through the thread guide on the thread stand (1).
2. Pull the thread from left to right under the thread guide on the back of the top cover (2). Use the tweezers to make the threading easier.
3. While holding the thread with both hands, pass it between the tension discs and pull it down to make certain it is properly placed between the tension discs (3).
4. Continue to thread points (4-7).

Note: Be sure to pass the thread through the upper thread path of the thread guide (6).

5. Thread the eye of the right needle (8). Use the tweezers to make needle eye threading easier.
6. Pull about 10 cm of thread through needle eye to hang free.
7. Raise the presser foot and place the thread to the back, under the presser foot.

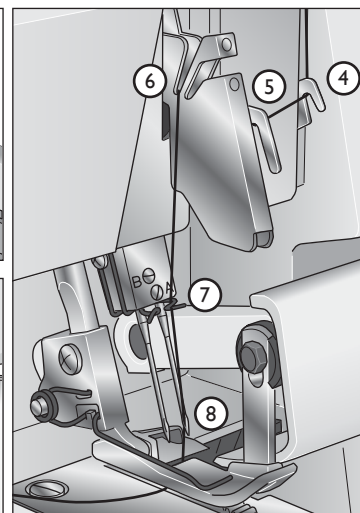
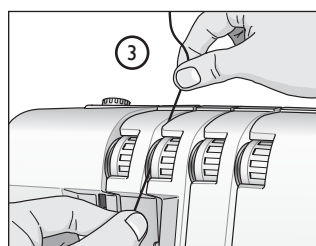
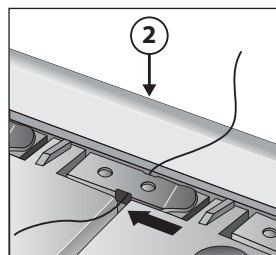
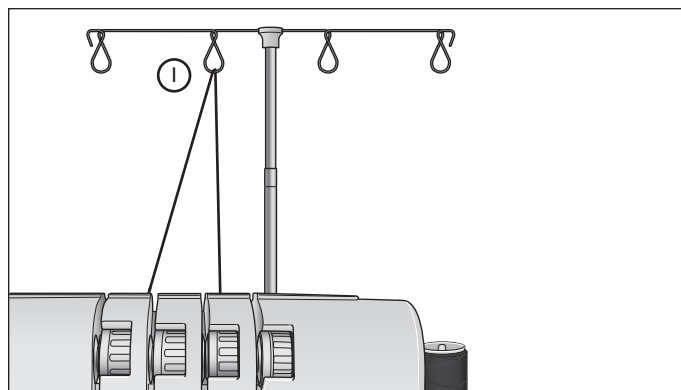

Threading the left needle (blue)

1. Pass the thread from back to front through the thread guide on the thread stand (1).
2. Pull the thread from left to right under the thread guide on the back of the top cover (2). Use the tweezers to make the threading easier.
3. While holding the thread with both hands, pass it between the tension discs and pull it down to make certain it is properly placed between the tension discs (3).
4. Continue to thread points (4-6).

Note: Be sure to pass the thread through the lower thread path of the thread guide (5).

5. Thread the eye of the left needle (7). Use the tweezers to make needle eye threading easier.
6. Pull about 10 cm of thread through needle eye to hang free.
7. Raise the presser foot and place the thread to the back, under the presser foot.

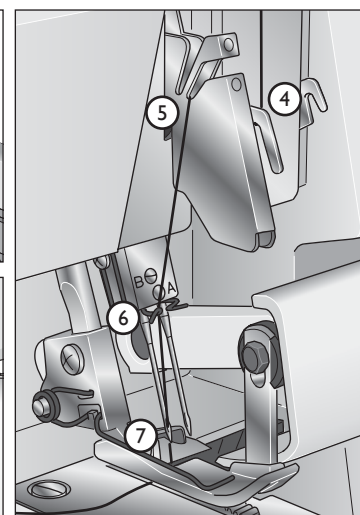
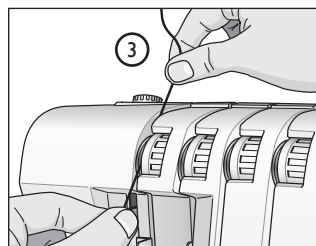
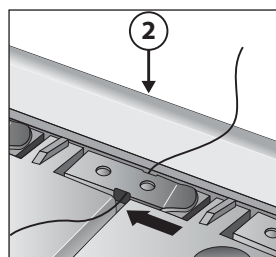
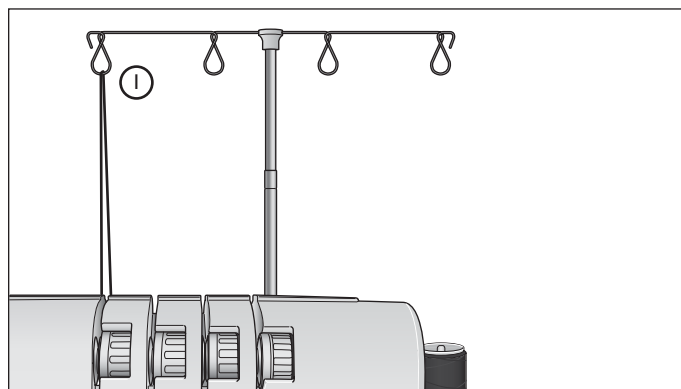

Changing thread

The following is an easy way to change threads:

1. Cut the thread in use near the spool, behind the guides on the telescopic thread stand.
2. Remove the thread spool and place the new thread on the spool pin.
3. Tie the end of the new thread to the end of the old thread. Cut the thread tails to 2-3 cm in length and firmly pull both threads to test knot security.
4. Raise the presser foot.
5. First note tension dial settings and then turn the tension dials down to "0".
6. Pull the threads through the machine one at a time until the knots are in front of the needle. If the threads do not pull easily, check for tangles on thread guides or looping under thread stand.
7. Cut the thread behind the knot and thread the needle.
8. Return tension dials to previous settings.

Note: When using standard thread spools, place the thread unreeling disc as shown to prevent the thread from getting caught on the edge of the spool.

Start sewing

1. When the machine is completely threaded, close the front cover and bring all of the threads over the stitch plate and slightly to the left under the presser foot.
2. Ensure that the upper blade moves against the lower blade correctly by turning the handwheel slowly toward you. If the blades are not moving correctly, check if there are any fabric or waste thread stuck between the blades.
3. Hold the threads and apply a slight tension.
4. Turn the hand wheel toward you 2 or 3 complete turns to start making a thread chain. Check if all threads wind around the stitch finger of the stitch plate. If the threads do not wind around the finger, make sure each thread is threaded correctly.
5. Continue holding the thread chain while pressing the foot control. Sew until the chain is 5-8 cm in length.
6. Place fabric under the front of the presser foot and sew a test sample. Guide the fabric slightly with your left hand while sewing. Do not pull on the fabric as this may deflect the needle, causing it to break.
7. When you reach the end of the fabric, continue sewing while drawing the finished fabric gently backwards and to the left. This is called chaining off. It prevents the threads from coming undone and prepares for next sewing.
8. Cut off the thread chain 2-5 cm behind the presser foot using the thread cutter on the left side of the machine. Pull the threads around the thread cutter from the back, then toward you.

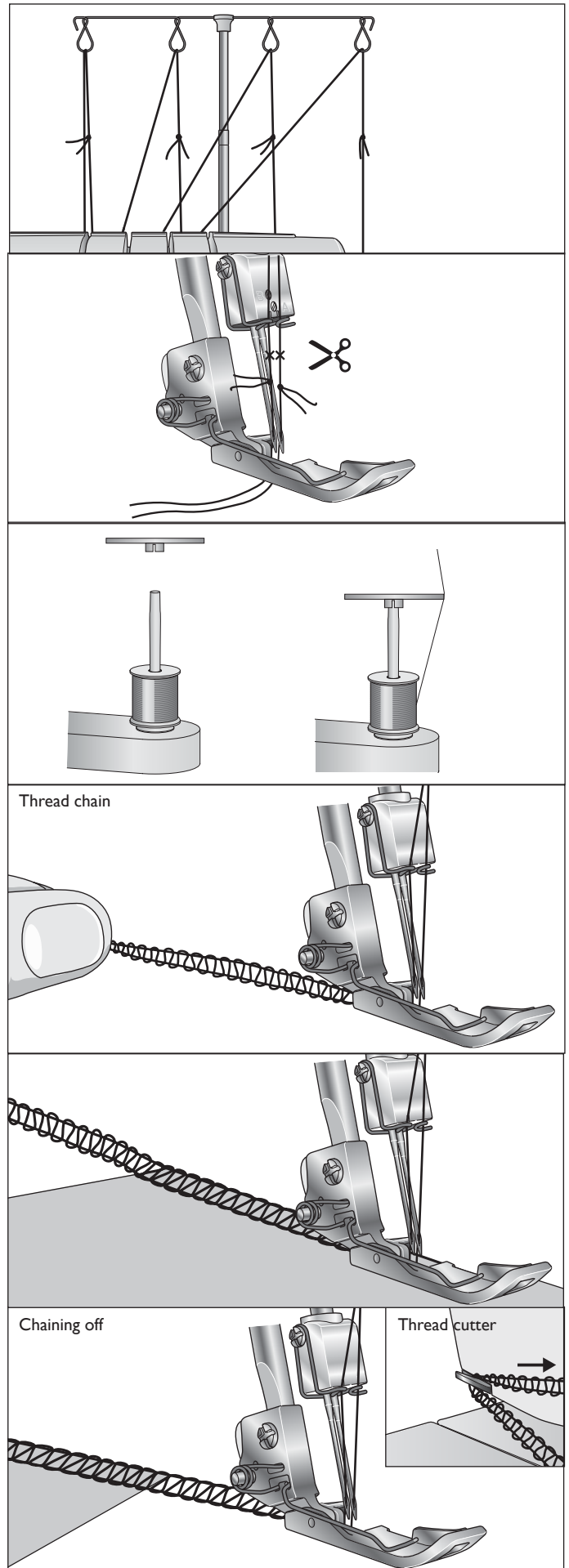

Thread tension settings

Set the thread tension to suit the type of fabric and thread used. As the number on the thread tension discs increases, the thread tension becomes tighter.

Lower looper thread and upper looper thread should be well balanced with the same tension (both looper threads should cross at the edge of the fabrics). Needle threads should not be too loose or too tight, but equally balanced tension.

See the stitch table on pages 23-26 for thread tension recommendations for each stitch.

When the upper looper thread is too loose

The upper looper thread is unbalanced when it is pulled to the wrong side of the fabric. Tighten the thread tension of the upper looper (purple) or loosen the thread tension of the lower looper (yellow).

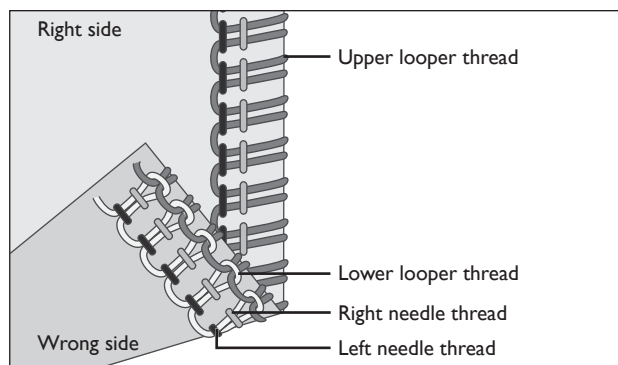
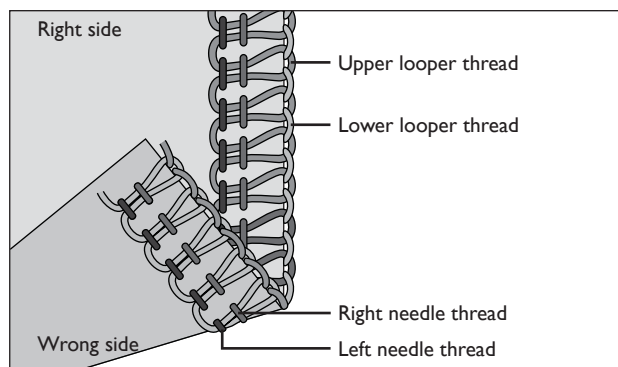

When the lower looper thread is too loose

The lower looper thread is unbalanced when it is pulled to the right side of the fabric. Tighten the thread tension of the lower looper (yellow) or loosen the thread tension of the upper looper (purple).

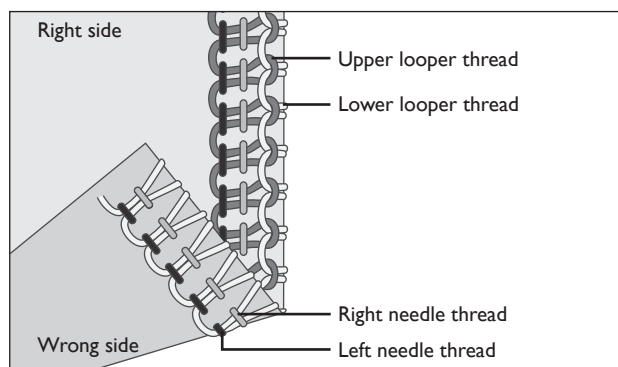

When the left needle thread is too loose

The left needle thread is too loose, tighten the thread tension of the left needle (blue) or loosen both looper threads (purple and yellow).

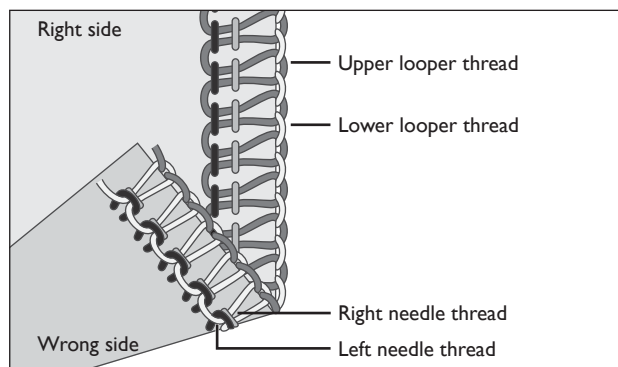

When the right needle thread is too loose

The right needle thread is too loose, tighten the thread tension of the right needle (green).

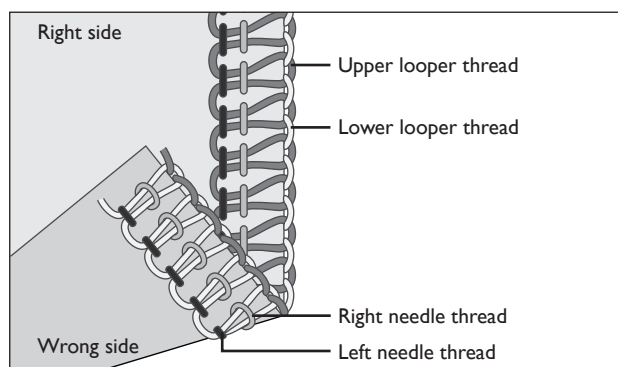

Differential feed adjustment

The differential feed system consists of two sets of feed teeth arranged one behind the other. Both feed teeth work independently of each other to give perfect results when sewing on speciality fabrics. When the amount of feed by the front feed teeth is changed in relation to the feed by the rear feed teeth it will “stretch” or “gather” the fabric.

Use the differential feed to prevent stretching of knit fabrics and puckering of lightweight fabrics.

For overlock stitching on normal fabric, set the differential feed adjusting lever to 1.0.

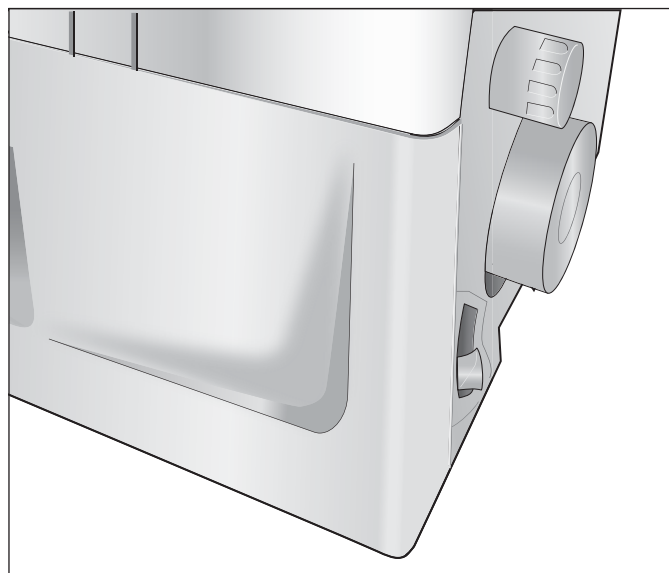

Gathered overlock (stretch, knit fabrics)

When overedging stretch fabric, such as knits and jersey, adjust the differential feed to a number between 1.0 and 2.0. The setting depends on the fabric being sewn. Test sew with different settings before sewing on your project.

Stretch overlock (lightweight fabrics)

When overedging light woven or loosely knit fabrics, such as silk and silky knitwear, adjust the differential feed to a number between 0.7 and 1.0. When sewing, apply gentle tension to the fabric by holding the seam lightly in front and back of the presser foot. The setting depends on the material being sewn as well as the wished amount of stretching. Therefore, test sew with different settings before sewing on your garment.

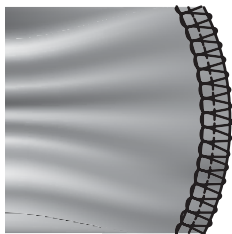
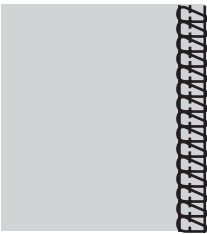
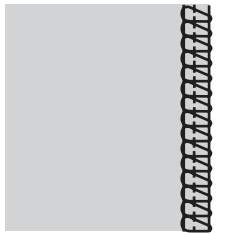
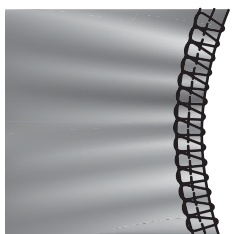
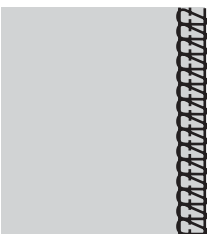
Fabric	Differential feed 1.0	Adjustment	Result
Stretch fabric (Knit, jersey)		1.0 - 2.0	
Non-stretch fabric (Chino, denim)		1.0	
Lightweight fabric (Silk, silky knitwear)		0.7 - 1.0	

Presser foot pressure adjustment

The presser foot pressure is pre-set for sewing based on normal conditions. Adjustment might in some conditions be necessary. Increase or decrease the pressure until you are satisfied with the result. Always test sew on a sample of your fabric before sewing on your garment.

Less pressure: Decrease the pressure by turning the adjustment tool in counter-clockwise direction.

More pressure: Increase the pressure by turning the adjustment tool in clockwise direction.

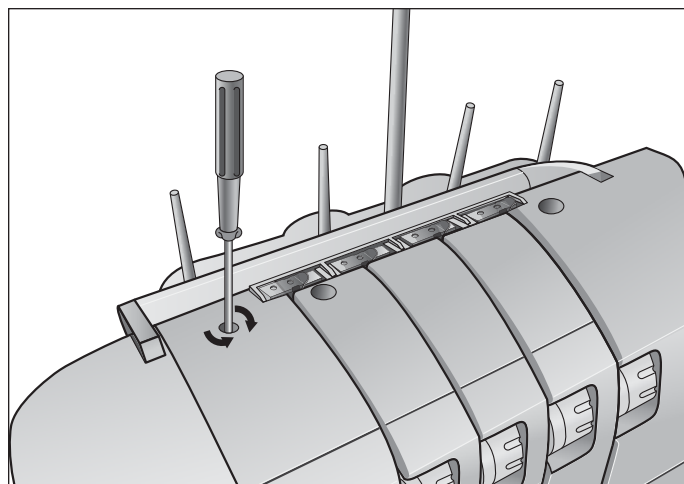

Stitch width settings

The stitch width can be increased or decreased by changing the needle position or with the width adjustment knob.

Width adjustment by changing needle position

A) When only the left needle, or when both needles are used the stitch width is 5.7 mm.

B) When only the right needle is used the stitch width is 3.5 mm.

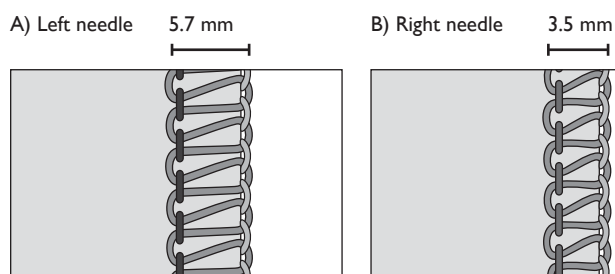

Width adjustment with the width adjustment knob

By fine tuning the cutting width, using the width adjustment knob further adjustment are possible within the range shown below:

A) When only the left needle is used: 5.2 - 6.7 mm

B) When only the right needle is used: 3.0 - 4.5 mm

Turn the knob to adjust the desired seam width, using the graduations on the stitch plates as a guideline.

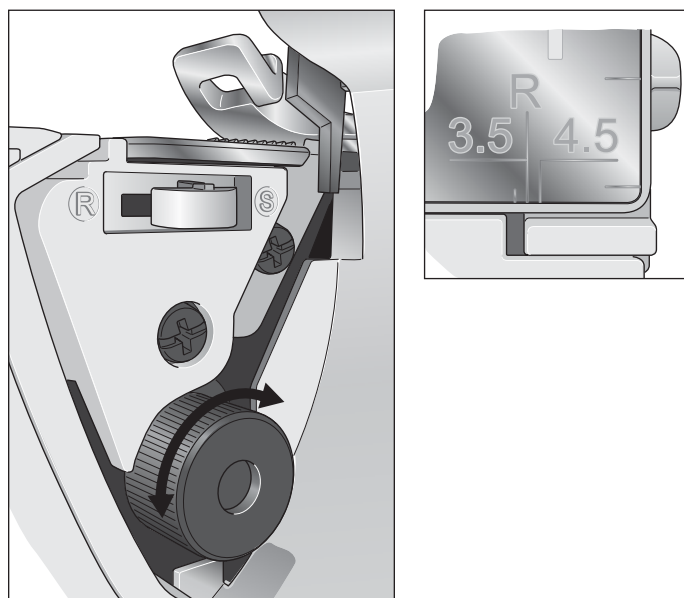

Stitch length settings

The stitch length dial should be set on “3” for most sewing. Adjust the stitch length to 4 mm when sewing on heavy weight fabrics. Adjust the stitch length to 2 mm when sewing on light weight fabrics.

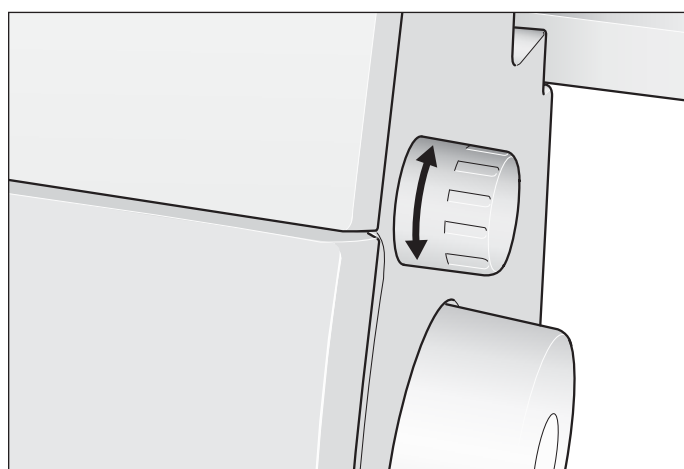

Stitch finger lever setting

The stitch finger lever should be set to “S” for all standard overlock sewing. To sew rolled edge you need to retract the stitch finger by setting the stitch finger lever to “R”. When moving the stitch finger, be sure to push the lever as far as it will go in each direction.

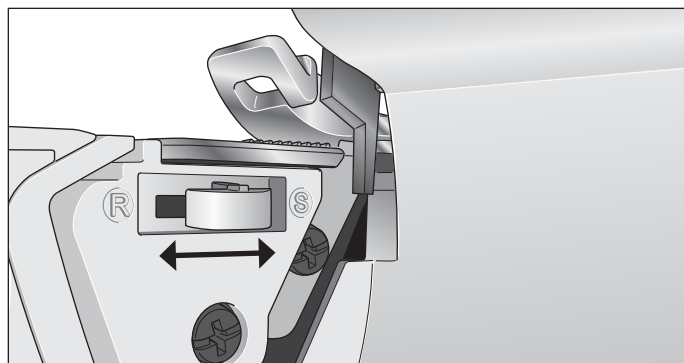

Rolled edge sewing

The rolled edge stitch is appropriate for light weight fabrics such as lawn, voile, organdy, crepe, etc. The rolled edge is achieved by adjusting the thread tension to make the fabric edge roll under the fabric while overlocking. Adjust the thread tension to change the degree of rolling. To sew rolled edge you need to set the stitch finger lever to “R”. The minimum overlock stitch width that can be obtained for rolled edging is approximately 1.5 mm since the cutting width cannot be set below 3.5 mm.

A variant of the rolled edge stitch is the narrow edge. It can be obtained by adjusting the thread tension according to the stitch table on pages 23-26.

Tip: For a beautiful rolled edge, thread the upper looper with a decorative thread and the needle and lower looper with lightweight regular thread.

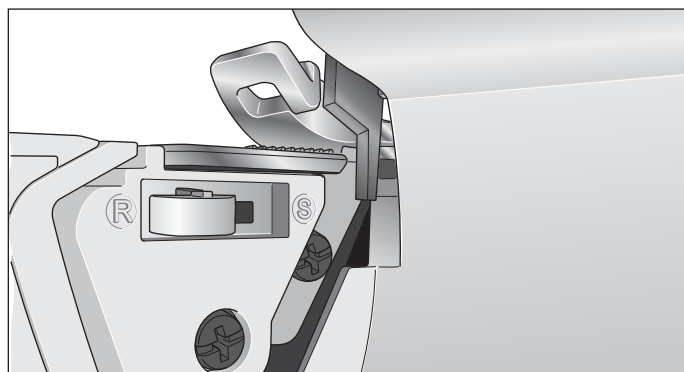

2-thread rolled edge / narrow edge

1. Attach the 2-thread overlock converter (see page 8).
2. Use the right needle thread and lower looper thread.
3. Move the stitch finger lever to “R”.
4. Set the stitch length dial to “3-2” for a fine seam.
5. Set the thread tension according to the stitch table on pages 23-26.
6. Make a thread chain and test sew on a sample of your fabric before sewing on your garment. Hold the thread chain while beginning to sew to keep it from curling into the seam.

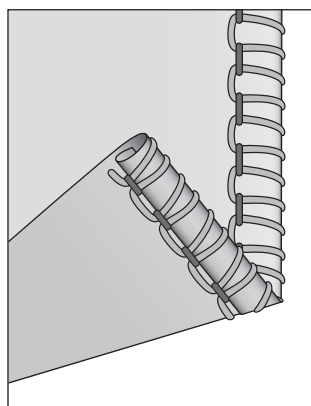

2-thread rolled edge

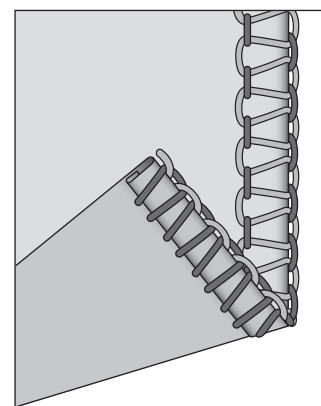

2-thread narrow edge

3-thread rolled edge / narrow edge

1. Use the right needle thread and the upper and lower looper threads.
2. Move the stitch finger lever to “R”.
3. Set the stitch length dial to “3-2” for a fine seam.
4. Set the thread tension according to the stitch table on pages 23-26.
5. Make a thread chain and test sew on a sample of your fabric before sewing on your garment. Hold the thread chain while beginning to sew to keep it from curling into the seam.

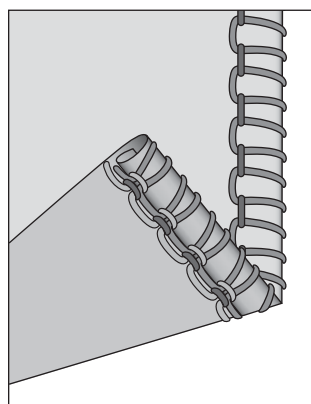

3-thread rolled edge

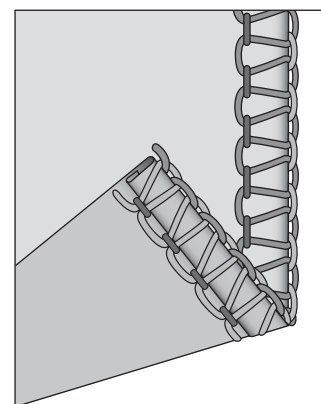

3-thread narrow edge

Flatlock sewing

A Flatlock Stitch is made by adjusting the tension of the 2- or 3-thread overlock stitch, sewing the seam and pulling the fabric apart to flatten the seam. The tensions must be adjusted correctly for the fabric to pull flat.

The Flatlock Stitch can be used both as a decorative construction stitch, sewing two pieces together (Standard Flatlock Stitch), or for ornamentation only on one piece of fabric (Ornamental Flatlock Stitch).

There are two ways to sew a Flatlock Stitch. Either with the wrong sides of the fabric together to create a decorative look, or with the right sides together, to create a Ladder Stitch.

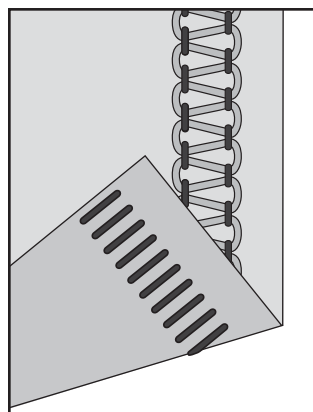

2-thread flatlock stitch

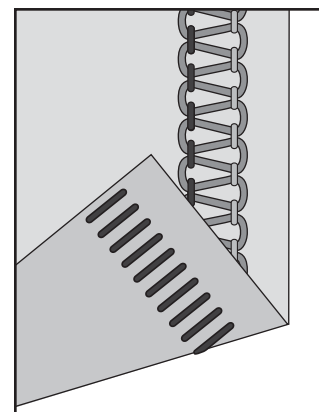

3-thread flatlock stitch

Standard Flatlock Stitch

1. Use the left needle.
2. For 2-thread Flatlock: Attach the 2-thread converter (see page 8). Thread the lower looper and the left needle.
For 3-thread Flatlock: Thread the lower and upper looper and the left needle.
3. Set the thread tension according to the stitch table on pages 23-26.
4. Place the wrong sides of the two pieces of fabric together to sew a decorative stitch on the right side of the garment.
5. Sew the seam, trimming the excess fabric. The needle thread will form a V on the underside of the fabric. The lower looper thread will pull into a straight line at the fabric edge.
6. Unfold the fabric and pull on opposite sides of the seam to pull the stitches flat.

Ornamental flatlock stitch

1. Place the movable upper cutter in the nonworking position. The fabric should not be trimmed on this stitch.
2. Follow steps 1-3 above.
3. Fold the fabric piece, wrong sides together, to sew a decorative stitch on the right side of the garment.
4. Position the fabric so the seam is sewn with part of the stitch extending off the fabric.
5. Unfold the fabric and pull on opposite sides of the stitch to flatten.

Tip: The upper looper thread is the prominent thread in the flatlock stitch. Place a decorative thread in the upper looper and regular threads in the lower looper and needle.

Ladder stitch

To create a ladder stitch, sew with right sides of the fabric together. The needle thread will be the prominent thread that creates the ladder.

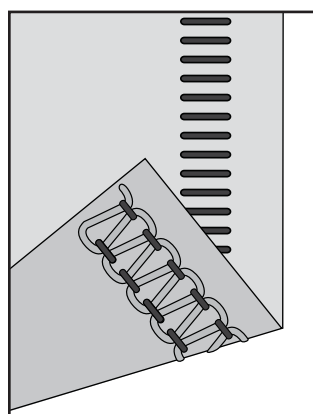
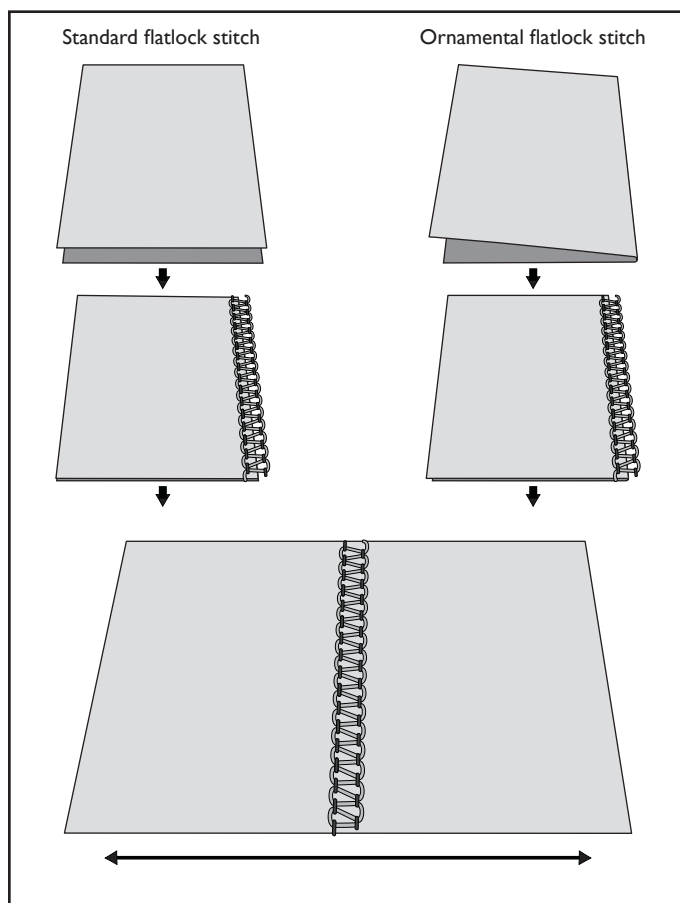

2-thread ladder stitch

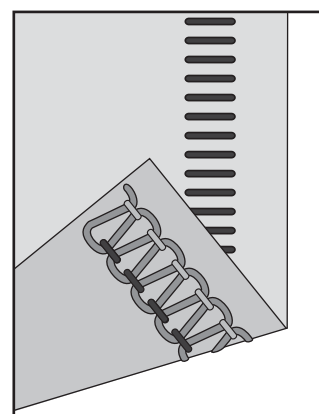

3-thread ladder stitch

Corded overlock

Corded overlock can be used to strengthen stitches when joining elastic fabrics such as knits. Cording prevents knit fabrics from stretching and also stabilize the seams.

1. Insert the cord through the hole in the front of the foot.
2. Position the cord under the foot to the back of the machine and sew the garment seam.
3. The cord is attached in the stitch as the seam is sewn.

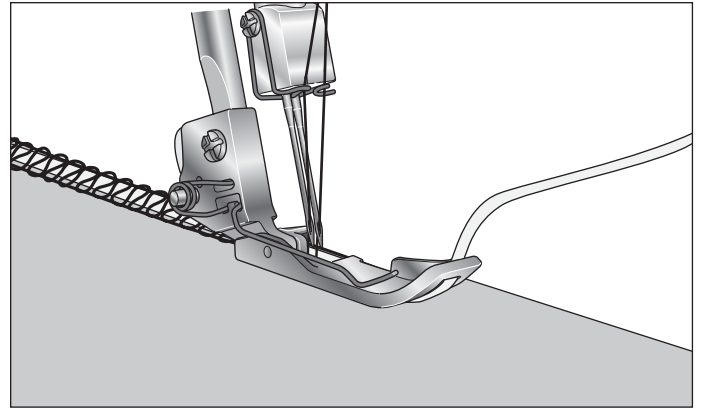

Pin placement

Insert straight pins to the left of the presser foot. The pins will be easy to remove and are away from the cutters.

Warning: Sewing over pins will damage and might destroy the edge of the cutters.

Securing the thread chain

1. Thread the chain into a large eyed, hand sewing needle.
2. Insert the needle into the end of the seam and pull the chain into the seam to secure the threads.

Machine maintenance

An overlock requires more frequent maintenance than a conventional machine for two reasons:

- A lot of lint is produced when the cutters are cutting the fabric.
- An overlock runs at a very high speed and needs to be oiled frequently to lubricate the internal working parts.

Cleaning



Turn off the main power switch and unplug the machine.

Open the front cover and remove all the lint using the lint brush from the accessory case.

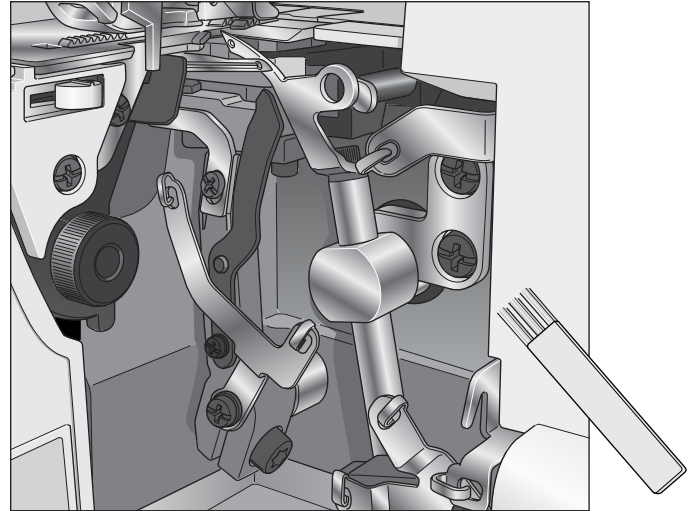

Oiling



Turn off the main power switch and unplug the machine.

To keep the machine running smoothly and quietly the moving parts, pointed out in the picture, must be lubricated often.

Use sewing machine oil. Do not use any other oil, it could damage the machine.

Wipe the machine surface to remove all excess oil before sewing.

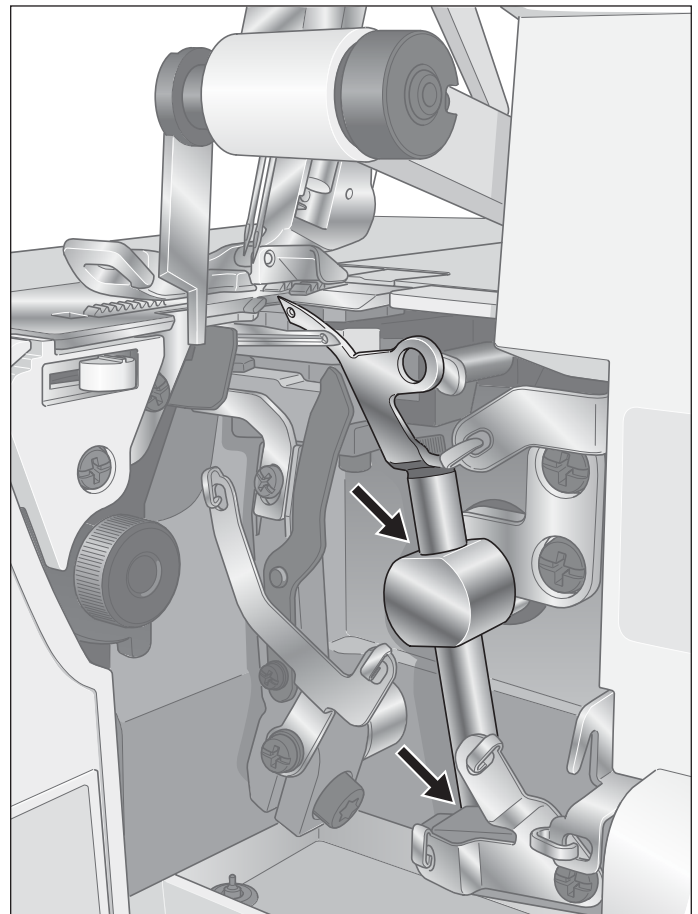

Replacing the stationary cutter

 *Turn off the main power switch and unplug the machine.*

The stationary cutter should be changed when it becomes dull. The stationary cutter can be replaced according to the following directions. If you are having any difficulties, consult your dealer to make the necessary adjustments.

1. Open the front cover and set the movable upper cutter (1) in nonworking position.
2. Loosen the stationary cutter set screw (2) and remove the stationary cutter (3).
3. Place a new stationary cutter in the groove of the stationary cutter holder.
4. Tighten the stationary cutter set screw (2).
5. Return the movable upper cutter (1) to its working position.
6. Turn the handwheel so the needles are in their lowest position.
7. Make sure the front edge of the movable upper cutter is 1-2 mm lower than the cutting edge of the stationary cutter.

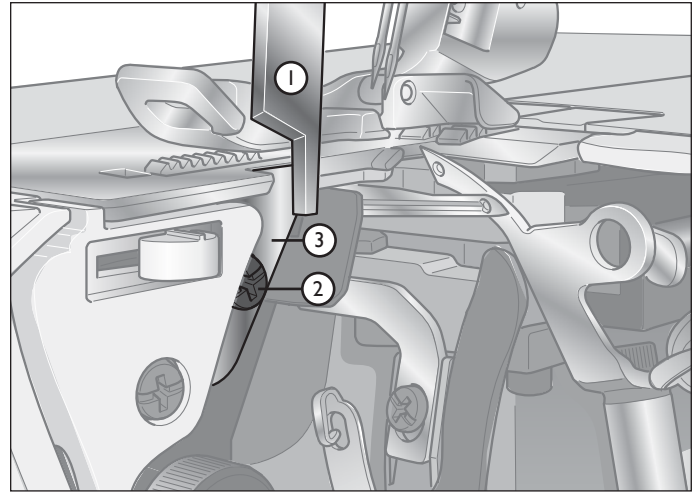

Storage

When the machine is not in use, be sure to keep it unplugged. Cover the machine with the vinyl cover to protect it from the dust. Store the machine, so it is not exposed to direct sunlight or humidity.

Servicing







If you have any questions regarding service and/or operation, contact the store where the machine was purchased.

Trouble shooting











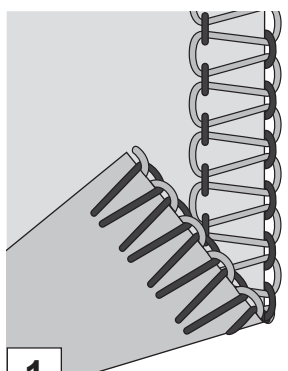





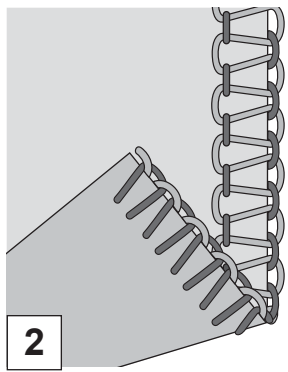

Problem	Solution	Page
Fabric does not feed well	- Lengthen stitch length.	17
	- Increase presser foot pressure for heavy weight fabric.	17
	- Decrease presser foot pressure for light weight fabric.	17
	- Check the differential feed.	16
Needle breaks	- Insert needle correctly.	8
	- Do not pull fabric while sewing.	14
	- Tighten needle set screw.	8
	- Use a larger size needle on heavy fabrics.	8
Thread breaks	- Check threading.	10-13
	- Check for tangled or caught thread.	
	- Insert needle correctly.	8
	- Insert new needle, current needle may be bent or have a blunt point.	8
	- Use high quality thread.	28
- Loosen thread tension.	15	
Stitches skip	- Insert new needle, current needle may be bent or have a blunt point.	8
	- Tighten needle set screw.	8
	- Insert needle correctly.	8
	- Change type or size of needle.	8
	- Check threading.	10-13
	- Increase presser foot pressure.	17
- Use a high quality thread.	28	
Irregular stitches	- Balance thread tension.	15
	- Check for tangled or caught thread.	
	- Check threading.	10-13
Fabric puckers	- Loosen thread tension.	15
	- Check for tangled or caught thread.	
	- Use high quality light weight thread.	28
	- Shorten stitch length.	17
	- Decrease presser foot pressure for light weight fabrics.	17
- Check the differential feed.	16	
Irregular trimming	- Check alignment of the cutters.	22
	- Replace one or both cutters.	22
Fabric jams	- Be sure the cutters are in sewing position.	
	- Check for tangled or caught thread.	
	- Compress thick layers of fabric with conventional machine before sewing with overlock.	
Machine does not operate	- Connect machine to power source correctly.	6



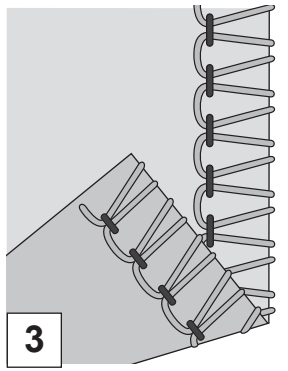







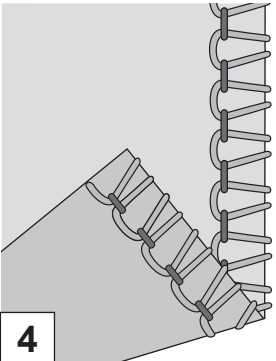





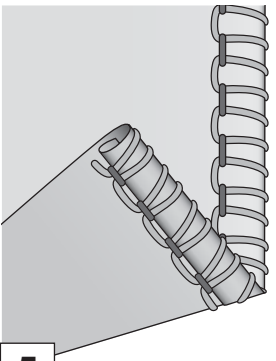





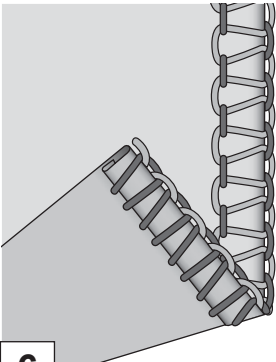

Stitch table



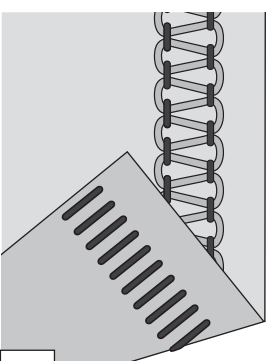







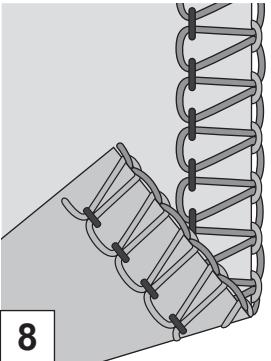







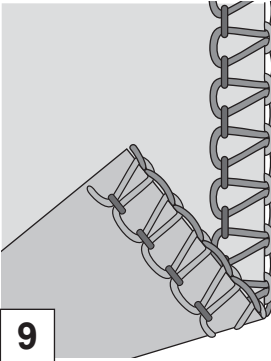







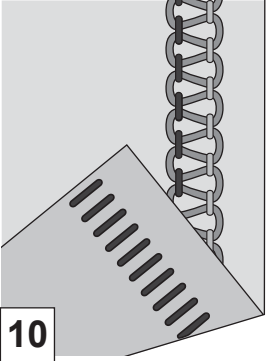





Explanation of the fabric symbols

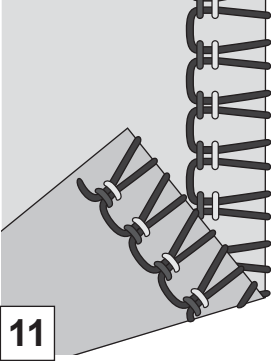









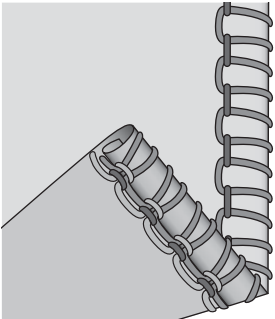





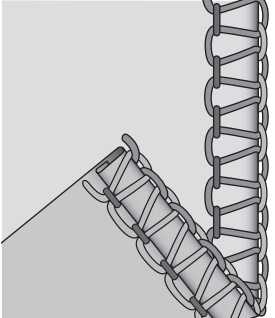





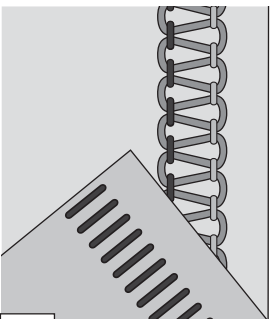

	Woven light Chiffon, voile, organza, batiste, silk, etc.		Stretch light charmeuse, nylon, tricot, single knit jerseys, etc.
	Woven medium Cotton, chino, wool, satin, etc		Stretch medium double knit, velour, swimwear, etc.
	Woven heavy denim, canvas, terrycloth, etc.		Stretch heavy sweater knits, fleece, etc.

Please note:
The settings shown in this table are our recommendations based on normal conditions. It may be necessary to adjust the thread tension according to the stitch, type of fabric and thread you are using. For best results make tension adjustments in small increments of no greater than half a number at a time. Always test sew on a sample of your fabric before sewing on your garment.

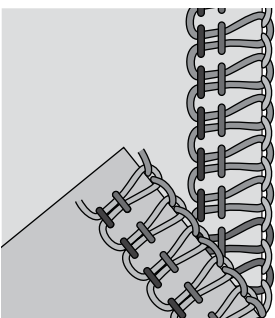
Combination		Needle position	Stitch length	Stitch width	Differential feed	Stitch finger	2-thread converter	Thread tension			
Stitch	Fabric							B	G	P	Y
2-thread overlock, wide  1		Left	3	R(3.5)	1.0	S	Yes	0.0	-	-	5.0
								0.5	-	-	5.0
								3	-	-	5.0
								0.0	-	-	5.0
								3	-	-	5.0
					1.5			3	-	-	5.0
2-thread overlock, narrow  2		Right	3	R(3.5)	1.0	S	Yes	-	0.0	-	4.0
								-	0.5	-	5.0
								-	3	-	5.0
								-	0.0	-	4.5
								-	0.5	-	4.5
					1.5			-	3	-	5.0
2-thread overlock, wrap, wide  3		Left	3	R(3.5)	1.0	S	Yes	2.5	-	-	3
								3.5	-	-	3
								4.0	-	-	3
								2.5	-	-	3
								3.5	-	-	3
					1.5			4.0	-	-	3

Combination		Needle position	Stitch length	Stitch width	Differential feed	Stitch finger	2-thread converter	Thread tension			
Stitch	Fabric							B	G	P	Y
2-thread overlock, wrap, narrow 		Right	3	R(3.5)	1.0	S	Yes	-	3.5	-	2.0
								-	4.0	-	2.0
								-	5.0	-	2.0
								-	3	-	2.0
								-	4.0	-	2.0
					-			5.0	-	2.0	
2-thread rolled edge 		Right	1	3	1.0	R	Yes	-	3	-	2.0
								-	3	-	2.0
		Not recommended									
		Right	1	3	1.0	R	Yes	-	3	-	2.0
		Not recommended									
		Not recommended									
2-thread narrow edge 		Right	1	3	1.0	R	Yes	-	1.5	-	4.0
								-	1.5	-	4.0
		Not recommended									
		Right	1	3	1.0	R	Yes	-	2.0	-	4.0
		Not recommended									
		Not recommended									
2-thread flatlock stitch 		Left	3	R(3.5)	1.0	S	Yes	0.0	-	-	5.0
								0.5	-	-	5.0
								3	-	-	5.0
								0.0	-	-	5.0
								0.5	-	-	5.0
					1.5			3	-	-	5.0

Combination		Needle position	Stitch length	Stitch width	Differential feed	Stitch finger	2-thread converter	Thread tension			
Stitch	Fabric							B	G	P	Y
3-thread overlock stitch, wide  8		Left	3	R(3.5)	1.0	S	No	2.5	-	3	3
								3	-	3	3
								3.5	-	3	3
								2.5	-	3	3
								3	-	3	3
								3	-	3	3
					1.5			-	3	3	
3-thread overlock stitch, narrow  9		Right	3	R(3.5)	1.0	S	No	-	2.5	3	3
								-	3	3	3
								-	3.5	3	3
								-	2.5	3	3
								-	3	3	3
								-	3	3	3
					1.5			-	3	3	
3-thread flatlock stitch, narrow  10		Left	3	R(3.5)	1.0	S	No	4.0	-	0.0	8.0
								4.0	-	0.0	8.5
								5.0	-	0.0	8.5
								4.0	-	0.0	8.0
								5.0	-	0.0	8.5
								5.0	-	0.0	8.5
								5.0	-	0.0	8.5
3-thread stretch overlock  11		Right	3	R(3.5)	1.0	S	No	-	3	3	7.0
								-	3.5	3	7.0
								-	4.0	3	7.0
								-	3.5	3	6.0
								-	3.5	3	6.0
								-	3	3	6.0
								-	3	3	6.0

Combination		Needle position	Stitch length	Stitch width	Differential feed	Stitch finger	2-thread converter	Thread tension			
Stitch	Fabric							Y	R	G	B
3-thread rolled edge  12		Right	1	3	1.0	R	No	-	2.0	5.0	7.0
								-	2.0	5.0	8.0
		Not recommended									
		Right	1	3	1.0	R	No	-	3	4.0	6.0
		Not recommended									
		Not recommended									
3-thread narrow edge  13		Right	1	3	1.0	R	No	-	3	5.0	3
								-	3	5.0	4.0
		Not recommended									
		Right	1	3	1.0	R	No	-	3	5.0	3
		Not recommended									
		Not recommended									
3-thread flatlock stitch, wide  14		Left	3	R(3.5)	1.0	S	No	0.5	-	5.0	7.0
								0.5	-	5.0	7.0
								0.5	-	5.0	7.0
								0.5	-	5.0	7.0
								0.5	-	5.0	7.0
								0.5	-	5.0	7.0
4-thread overlock stitch  15		Both	3	R(3.5)	1.0	S	No	2.5	2.5	3	3
								3	3	3	3
								3.5	3.5	3	3
					2.5			2.5	3	3	
					3			3	3	3	
					3.5			3.5	3	3	

Fabric / Needle / Thread table

Fabric	Light fabric (voile, crepe, georgette, etc.)	Medium fabric (cotton, chino, wool, satin etc.)	Heavy fabric (denim, jersey, tweed etc.)
Needle	#12/80	#12/80, #14/90	#14/90
Thread	Polyester (spun filament) Twisted thread #60/2 - #80/2 (Twisted thread #80/3 - #100/3)	Twisted thread #60/2	Twisted thread #50/2 - #60/2

Specifications

Sewing speed	Maximum 1300 stitches/min
Stitch length	1.0-4.0 mm
Differential feed ratio	0.7-2.0
Overlock stitch width	Left needle: 5.2-6.7 mm Right needle: 3.0-4.5 mm Rolled hem: 1.5 mm
Needle bar stroke	27 mm
Presser foot rise	4.5 mm
Needles	SINGER Overlock Needles Style 2022, Size: #14/90
Number of needles	2
Number of threads	2, 3, 4
Type of lamp	LED light
Machine dimensions	
Width	301 mm
Depth	280 mm
Height	270 mm
Weight	6.0 kg

We reserve the right to change the machine equipment and the assortment of accessories without prior notice, or make modifications to the performance or design. Such modifications, however, will always be to the benefit of the user and the product.

INTELLECTUAL PROPERTY

SINGER, and the Cameo “S” Design, are exclusive trademarks of The Singer Company Limited S.à.r.l. or its Affiliates.



Please note that on disposal, this product must be safely recycled in accordance with relevant National legislation relating to electrical/electronic products. Do not dispose of electrical appliances as unsorted municipal waste, use separate collection facilities. Contact your local government for information regarding the collection systems available. When replacing old appliances with new ones, the retailer may be legally obligated to take back your old appliance for disposal free of charge.

If electrical appliances are disposed of in landfills or dumps, hazardous substances can leak into the groundwater and get into the food chain, damaging your health and well-being.



SINGER®

ORIGINAL SINCE 1851.