

ditto

Let's get started!

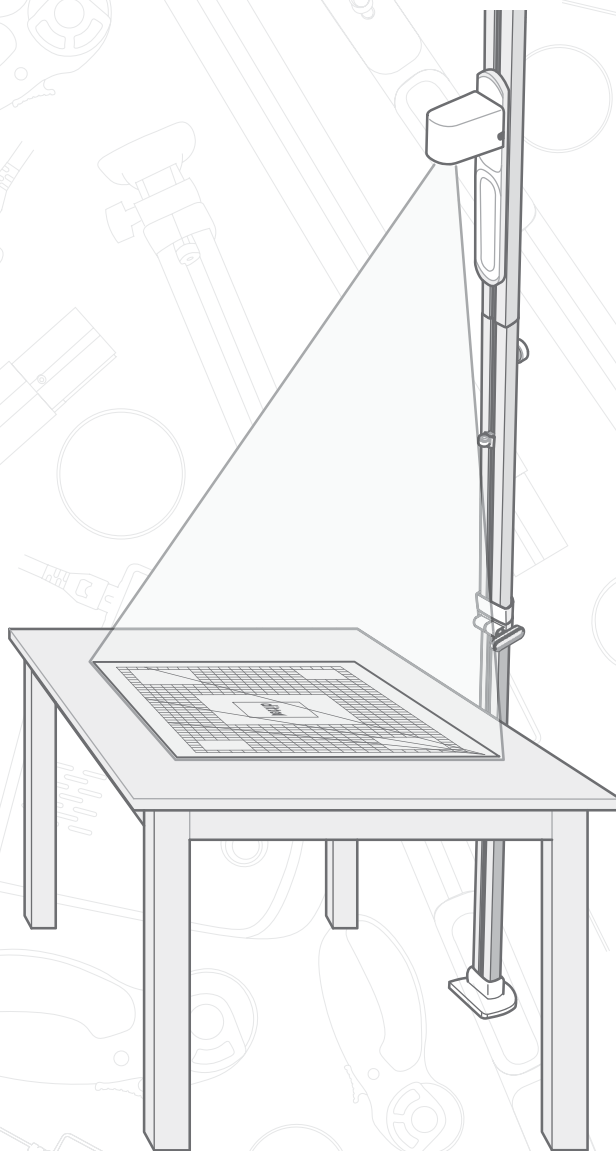

INSTRUCTION MANUAL

Singer® Ditto™



IMPORTANT SAFETY INSTRUCTIONS

General Safety Instructions

- Read and understand the instructions before you use the product.
- Keep the instructions at a suitable place close to the product. Make sure to hand them over if the product is given to a third party.
- This appliance is intended for use by adults. The appliance can be used with adult supervision by (i) children aged from 8 to 12 years and (ii) persons with reduced physical, sensory or mental capabilities or lack of experience and knowledge if they have been given instruction concerning the use of the appliance in a safe way and understand the hazards involved. Cleaning and user maintenance shall not be made by children without supervision. It is not allowed for anyone to play with the machine. Children up to 8 years are not allowed to use the machine.

WARNING –TO REDUCE THE RISK OF BURNS, FIRE, ELECTRIC SHOCK, OR INJURY TO PERSON:

Safety Instructions for Assembly

- Assembly requires technical knowledge. Speak to a person with the necessary knowledge if:
 - you are uncertain if the selected installation location is suitable.
 - you do not understand all parts of the assembly instructions.
 - you do not have the necessary technical knowledge.
- If you are uncertain about the assembly and/or the disassembly, do not assemble or disassemble the product alone. The product is large and if the product falls it can cause serious personal injury and/or damage.
- Do not install the product if any parts are missing or damaged. Contact customer service.
- To prevent injury, this product must be securely attached to the floor and ceiling in accordance with the assembly instructions.
- Keep children and pets at a suitable distance from the work area during installation and/or when adjustments are made.
- Do not attempt to change or modify the product without permission from the manufacturer.
- Do not climb on the product.
- Do not hang any objects from the product.

Safety Instructions for Operation

- Use this product only for its intended use as described in this manual. Use only attachments recommended by the manufacturer as contained in this manual.

- Never operate this product if it has a damaged cord or plug, if it is not working properly, if it has been dropped or damaged, or dropped into water. Return the product to the nearest authorized dealer or service center for examination, repair, electrical or mechanical adjustment.
- Never operate the product with any air openings blocked. Keep air openings of the product free from the accumulation of lint, dust, and loose cloth.
- Do not use outdoors.
- Do not use the product if it is wet.
- Do not look straight at the projector lens during operation. The intense light beam may damage your eyes.
- Do not block the projection lens or the air vent on the projector with any objects when the product is under operation as this could cause the objects to become heated and deformed or even cause a fire.
- Always stay on the floor when you take a picture of the cutting mat during calibration. There is a risk of falling if you stand on a chair, a table or similar. Allow enough room to stand back away from table or take the photo from a high angle.

Electrical Safety

- Do not expose products to wet conditions. Water entering a product will increase the risk of electric shock.
- Do not abuse the cord. Never use the cord for carrying, pulling or unplugging the product. Keep cord away from heat, sharp edges or moving parts. Damaged or entangled cords increase the risk of electric shock.
- Never leave the product unattended when plugged in. Always unplug this product from the electric outlet immediately after use and before cleaning or making any servicing adjustments mentioned in the instruction manual.
- Always secure the cord in cord management hook behind the bubble level.

Safety Instructions for Maintenance

- Never drop or insert any object into any opening.
- Do not unplug by pulling on cord. To unplug, grasp the plug, not the cord.
- The projector becomes hot during operation. Let the product become cool before maintenance.
- Do not attempt to refocus the projector. The system does not have a focus button and it is optimally focused for the projection distance as defined in the setup.
- Replace damaged, worn or broken parts. Always use original spare parts from the manufacturer. Other spare parts can cause damage to the product and increase the risk of accidents.

Safety Definitions

Warnings, cautions and notes are used to point out especially important parts of the manual.

⚠ Warning! If you do not follow these instructions, there is a risk of death or injury.

⚠ Caution! If you do not follow these instructions, there is a risk of damage to the product, other materials or the adjacent area.

Note! Information that is necessary for a given situation.

SAVE THESE INSTRUCTIONS

TABLE OF CONTENTS

IMPORTANT SAFETY INSTRUCTIONS..... 2

General Safety Instructions..... 2

Safety Instructions for Assembly 2

Safety Instructions for Operation..... 2

Electrical Safety 2

Safety Instructions for Maintenance 2

Safety Definitions..... 3

Product overview 4

Introduction 5

Document Description 5

Tutorials 5

Product Description..... 5

Intended Use 5

Terminology..... 5

Before you Assemble the Product..... 5

Download the Ditto App..... 5

To Prepare the Work Area 5

To Assemble the Beam..... 6

To Attach the Projector..... 7

To Assemble the Cutting Mat..... 7

To Connect the Product..... 8

To Adjust the Projection 8

To Attach the Cords..... 8

Operation 8

Before Operation..... 8

To Connect to Ditto App..... 8

Ditto App – Home Screen Overview 9

Ditto App – Start Menu Overview 9

Ditto App – Workspace Overview 10

To Connect the Ditto System 11

Home screen 11

Workspace..... 12

Reconnect Wi-Fi Connection..... 12

To Calibrate the Ditto System 12

To Select a Pattern Piece 13

To Remove a Pattern Piece or
Pattern Pieces from the Workspace 13

To Project the Pattern 13

To Splice a Pattern Piece 14

To Mirror a Pattern..... 15

To Convert a Cut-on-fold Pattern Piece 15

Disassembly 15

Maintenance 16

To Clean the Product..... 16

To Examine the Product for Damage 16

To Store the Product..... 16

Troubleshooting and FAQ..... 17

Troubleshooting..... 17

Frequently Asked Questions 19

Certification requirements..... 20

Federal Communication Commission
Interference Statement..... 20

Intellectual Property 21

Patents and Patent Applications 21

Warranty 21

PRODUCT OVERVIEW

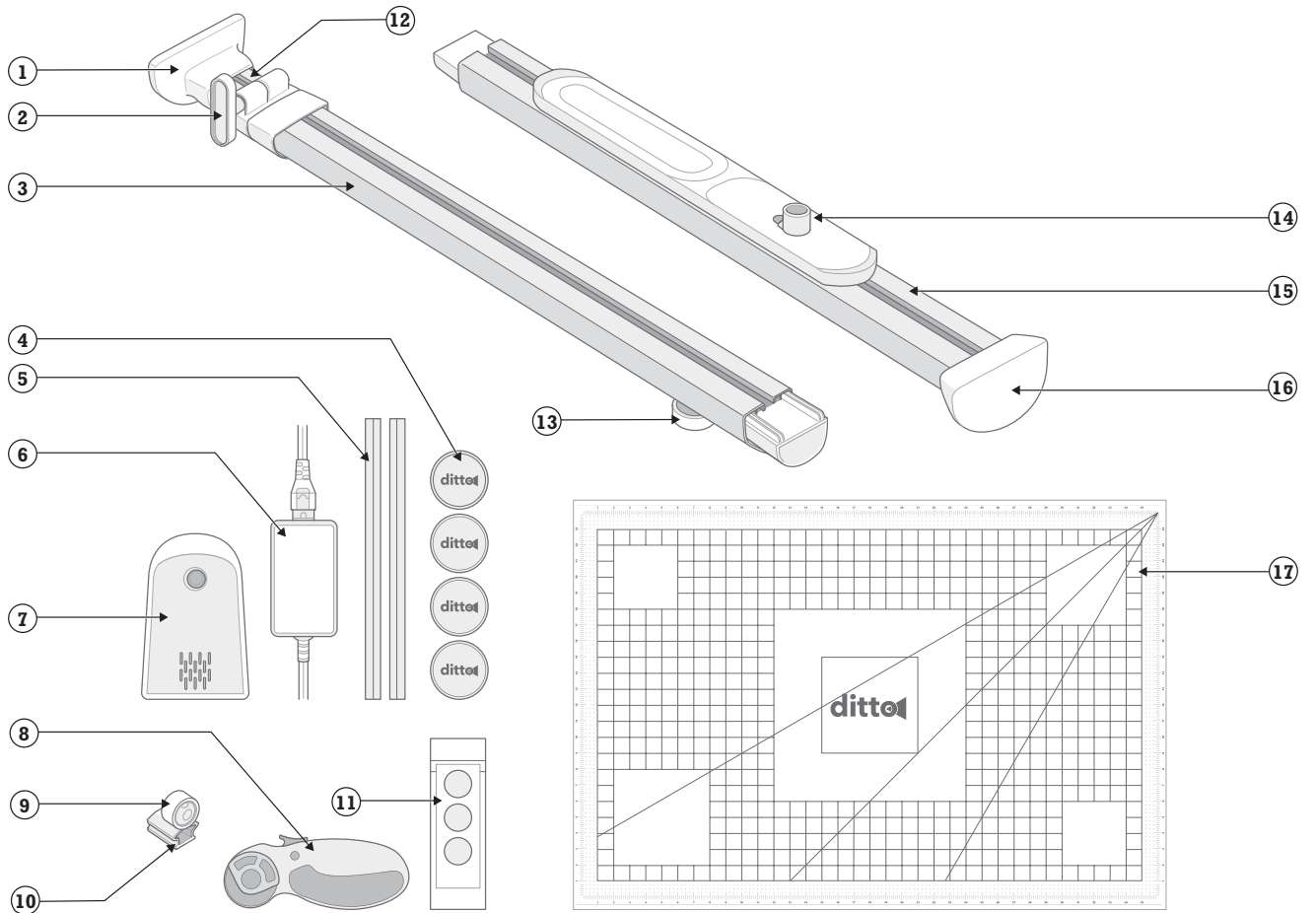

- | | | | |
|-----------------------|---------------------------|-------------------------------------|-----------------------|
| 1. Foot pad | 6. Power cord and adapter | 10. Cord management hook | 13. Lock knob |
| 2. Base knob | 7. Projector | 11. Target stickers | 14. Projector carrier |
| 3. Lower beam | 8. Rotary cutter | 12. Telescoping section of the beam | 15. Upper beam |
| 4. Fabric weights (4) | 9. Bubble level | | 16. Ceiling pad |
| 5. Cord covers | | | 17. Cutting mat |

INTRODUCTION

Document Description

This document contains instructions for setup, operation and maintenance of the product. Contact customer service for more information.

Tutorials

Video tutorial on how to setup your Ditto system, can also be found on the web at www.dittopatterns.com/tutorials

Product Description

This product is a beam mounted pattern projector. The product is wirelessly connected to your mobile device using the Ditto app and will project the pattern of your choice.

Intended Use

Optimal use and maintenance are described in these instructions. This product is not intended for industrial use.

Additional assistance, by region, may be found on the web at www.DittoPatterns.com or in the Ditto app under "Customer Service".

Terminology

Term	Meaning
Beam	The pole, that fits between floor and ceiling, that the Ditto projector attaches to.
Calibration	Optimizes your projector to produce a precise projection of the pattern piece onto the work area.
Mirroring	This function is the same as flipping the pattern piece. Mirror a pattern piece instead of cutting-on-fold. Use the Mirror vertical or mirror horizontal buttons in the Ditto app to flip a pattern piece.
Projector	A projector is an optical device that displays an image of the pattern pieces on your workspace onto a surface, such as the cutting mat or a piece of fabric. The projector enlarges the pattern pieces to a precise pattern in accurate size.
Splicing	When a pattern piece is too large for the workspace, it needs to be sectioned into two or more separate projections.

Term	Meaning
Splice target	Use the target stickers on the splice target projections when you splice a pattern piece. When you move your fabric to cut the next section, use the target stickers and target projections to keep the fabric pieces lined up properly, frame by frame.
Workspace	The area in the Ditto app where the pattern pieces are arranged for projecting onto the fabric.

SET UP

Before you Assemble the Product

1. Create an account at the Ditto web page on your computer. www.dittopatterns.com/signup
2. When registered and signed in on your computer, you can purchase and manage your subscription and patterns on the website.

Note! A computer is required for these tasks. Do not use a tablet or phone.

Download the Ditto App

1. Download the Ditto app on your mobile device.

Note! A mobile device is required for this task. Do not use a computer.

2. Register in the Ditto app.
3. Follow the instructions that are given in the Ditto app.

To Prepare the Work Area

Make sure that your work area meets these requirements:

- Flat work area with a minimum width of 37 in. x 25 in. (94 cm – 63cm)
- Flat ceiling with a minimum height of 7.5 ft. – 10 ft. (228 cm – 305 cm)
- Best possible Wi-Fi signal
- Power outlet within 10 ft. (3 m)
- Mobile device within 30 ft. (9 m) of the work area

Tip: Preferably use a tablet rather than a phone when using the Ditto system. The larger screen improves usability, making it easier to navigate the system, and increases legibility.

To Assemble the Beam

1. Press and hold the clips on the sides of the bubble level.
2. Slide the bubble level into the tracks of the lower beam with the bubble facing the joint to the upper beam.

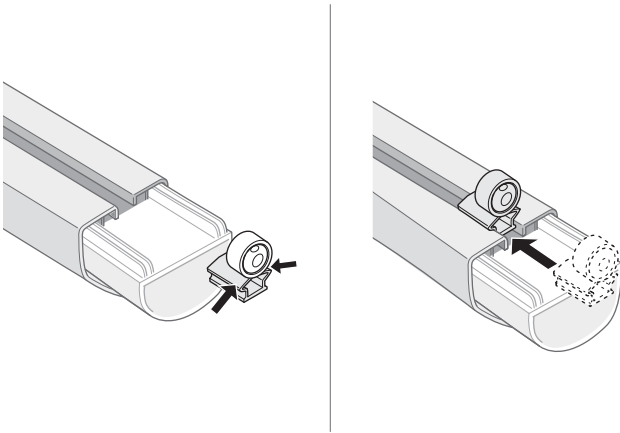

3. Slide the bubble level approximately 10 in. (25 cm) down the lower beam.
4. Put the lower beam and the upper beam on the floor or on a table.
5. Slide the lower beam and the upper beam together (A).
6. Push and turn the lock knob (B) clockwise to lock the beams together.
7. Loosen the base knob (C) of the beam to allow the spring loaded foot to extend.

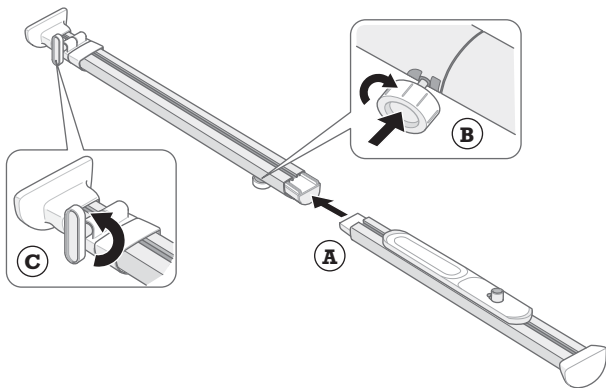

8. Lean the beam against a wall. Put the foot pad on the floor approximately 1 ft. (30 cm) from the wall.

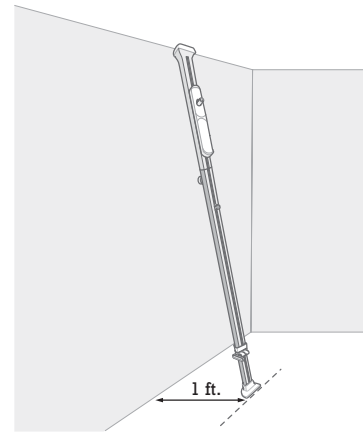

Note! Make sure that the height of the ceiling where you assemble the beam is the same as the height of the ceiling of the work area.

9. While standing on the foot pad, extend the telescoping piece and raise the beam until it touches the corner where the wall meets the ceiling. The telescoping base will extend as you raise the beam.

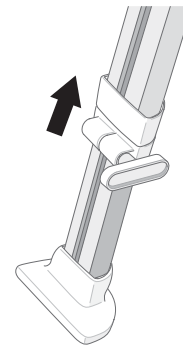

10. Tighten the base knob when the upper beam is touching the corner.
11. Now that the beam is set to the correct height, move the beam to the work area.

⚠ Caution! *Make sure that the beam is positioned in an area where it can not be easily be bumped into or hit while in operation mode.*

12. With the beam at an angle, position the foot of the beam about 1 in. (2.5 cm) from the workspace, ensuring the flat side of the beam is facing the work area.
13. Grip the beam and press it down towards the floor to depress the spring loaded foot.

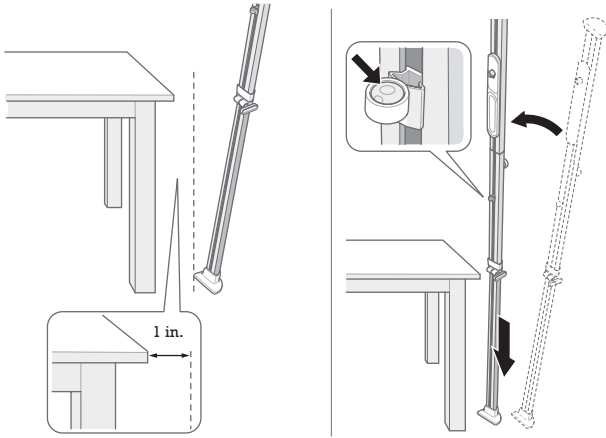

To Assemble the Cutting Mat

1. Unfold the cutting mat.
2. Put the cutting mat on the work area with the Ditto logo facing away from the beam.

⚠ Caution! The cutting mat must lay completely flat and fully on the work surface. Draping the mat off the edge of a surface will result in poor or incomplete calibration causing inaccurate pattern piece projection.

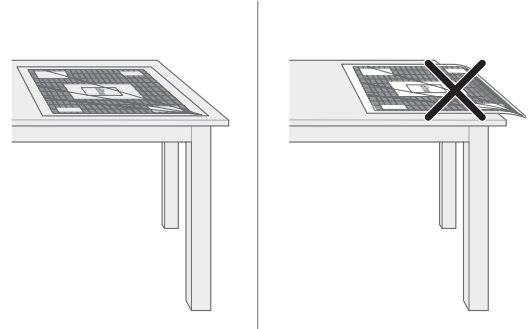

Note! Face the flat side of the beam towards the work area.

14. Position the beam vertically between the floor and the ceiling and release the beam.
15. Adjust the beam by pressing down, repositioning and releasing until the bubble in the bubble level is centered.

⚠ Warning! After assembly, ensure that beam is secured to both floor and ceiling. Carefully pull the beam by hand to make sure that the beam still stands steady between the floor and the ceiling. If not secure in place, there is a risk of the beam falling over and injuring people or causing damage to furniture or floors, etc.

To Attach the Projector

1. Slide the projector carrier to eye level.
2. Attach the projector to the projector carrier with the lens facing the ceiling.
3. Turn the projector 180 degrees counterclockwise until it clicks into place, facing downward.

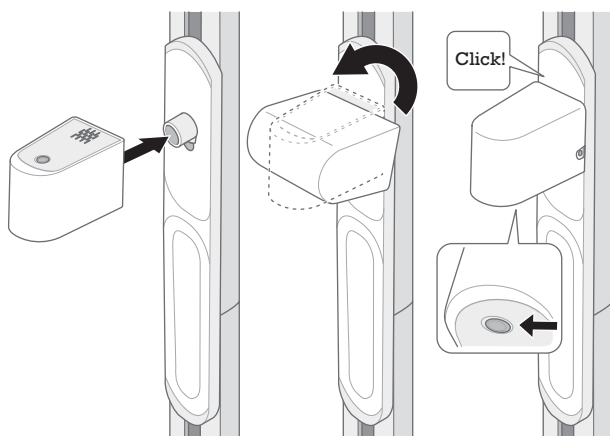

To Connect the Product

1. Connect the end of the power cord to the projector.
2. Connect the power cord for the projector in a grounded power outlet.

⚠ Caution! To disconnect the product from the power outlet, pull the plug, not the power cord.

To Adjust the Projection

When the product is connected to a power outlet, a red rectangle is projected onto the work area.

⚠ Caution! The red rectangle must be on top of the white frame region of the cutting mat.

Have your room dimly lit so the projected frame is vivid red.

- Slide the projector upwards to enlarge the size of the red rectangle.
- Slide the projector downwards to reduce the size of the red rectangle.

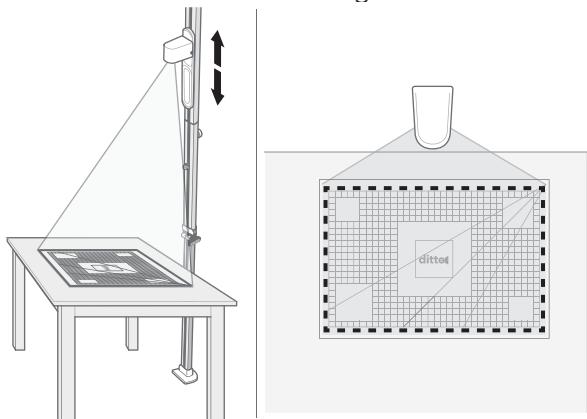

Note! Make sure that the bubble in the bubble level remains centered while sliding the projector.

Note! It is of high importance that the projection is fitted correctly on the cutting mat. It can take some attempts for the result to be satisfactory.

To Attach the Cords

1. Put the power cord into the cord management hook in the bubble level.
2. Put the power cord into the slot on the flat side of the beam.
3. Put the cord covers over the cord, into the slots and snap them into place.

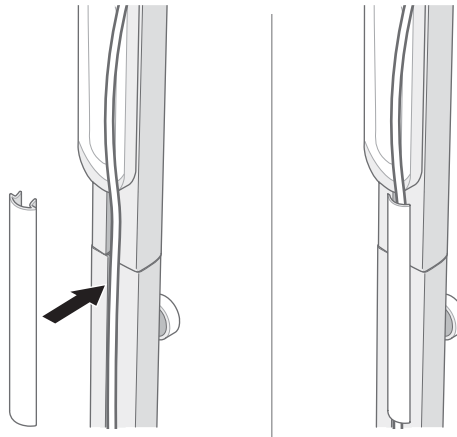

OPERATION

Before Operation

Have your room dimly lit so the projected outlines will be clearly visible.

To Connect to Ditto App

1. Log in to the Ditto app.

Note! You will remain logged in until you actively sign out.

Ditto App – Home Screen Overview



Hi there,

What would you like to do today?

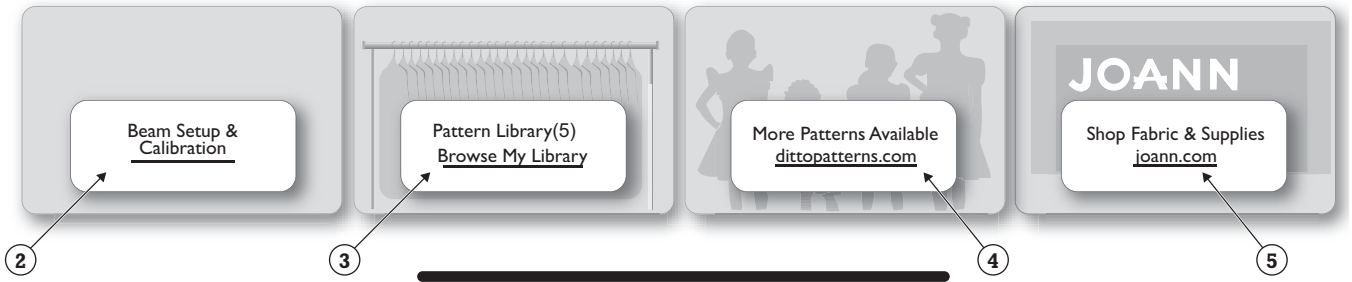

1. Start menu button
2. View Ditto tutorials
3. Pattern library (number of patterns)
4. Link to DittoPatterns.com to download more patterns
5. Link to www.Joann.com to shop fabric and supplies

Note! The look of the Ditto app might vary depending on what mobile device and software release you are using.

Ditto App – Start Menu Overview

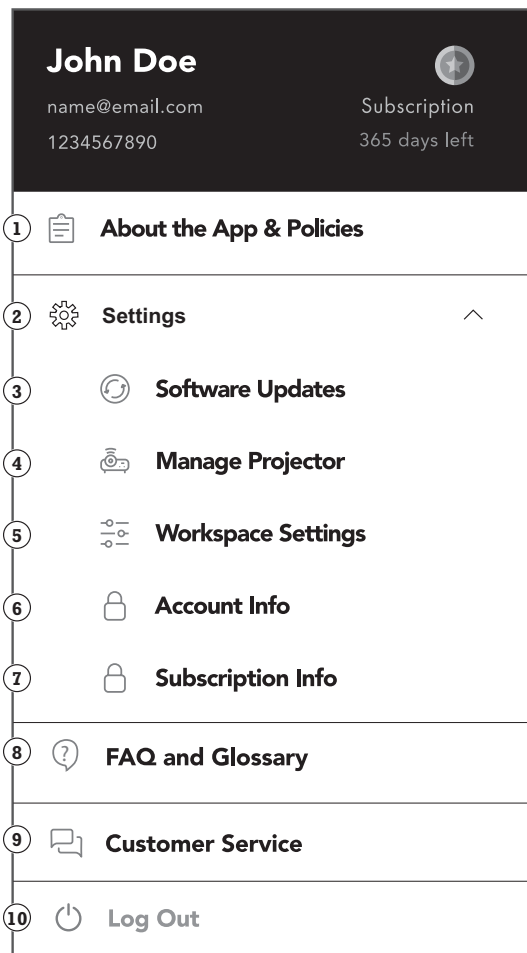

1. Information about the Ditto app, privacy policies and user terms.
2. Drop-down menu to access the Ditto system settings.
3. Check for and download the latest available Ditto system updates.
4. Pair the Ditto app to the projector.
5. Settings options in the workspace.
6. Information regarding your current user account.
7. Get information or edit your subscription.
8. Answers to frequently asked questions, glossary and tips for optimal use.
9. Contact information and customer service.
10. Sign out the logged-in user from the Ditto app.

Ditto App – Workspace Overview

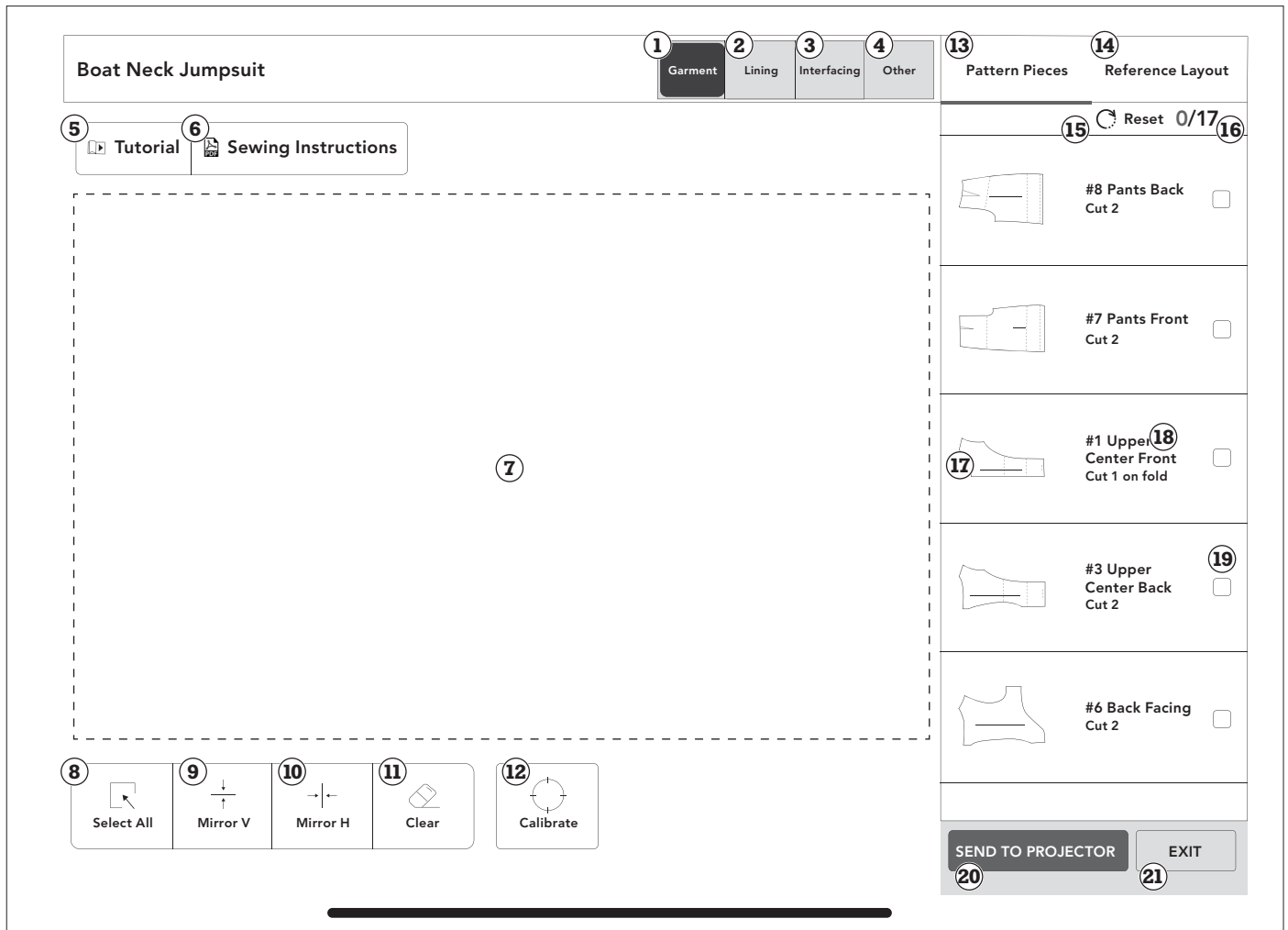

- | | | | |
|---|--------------------------------------|---|---|
| 1. Pattern component – Garment | 6. Written sewing instructions | 12. Connect to projector/ Calibrate the projector | 16. Number of completed pattern pieces |
| 2. Pattern component – Lining | 7. Workspace | 13. Selection of pattern pieces | 17. Pattern pieces |
| 3. Pattern component – Interfacing | 8. Select all button | 14. Reference layout / Spliced pattern piece map | 18. Cutting instructions for each pattern piece |
| 4. Pattern component – Other (notions, template pieces) | 9. Mirror vertical | 15. Reset button | 19. Checkbox |
| 5. Ditto written and video tutorials | 10. Mirror horizontal | | 20. Send the workspace to the projector |
| | 11. Clear selection in the workspace | | 21. Exit workspace button |

Gestures and Functions

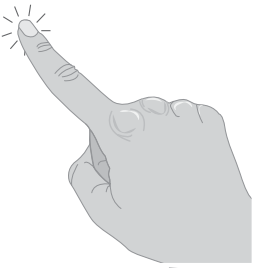
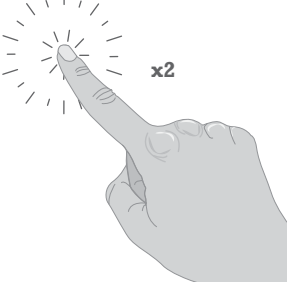
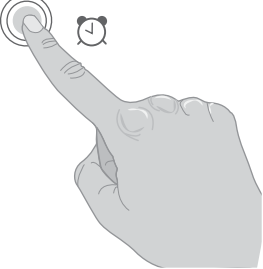
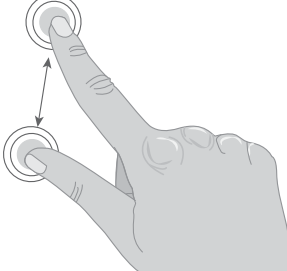
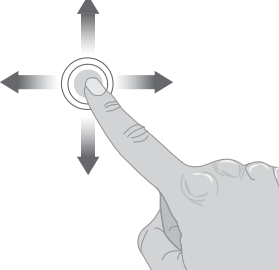
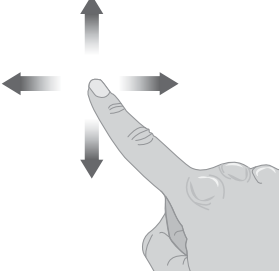

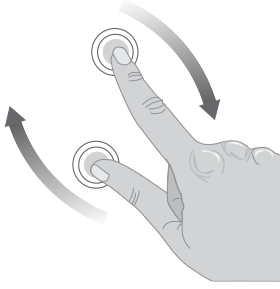
	<p>Tap</p> <p>Use 1 finger to select a command or a pattern piece.</p>
	<p>Double tap</p> <p>Use 1 finger and tap the pattern piece twice to enlarge a thumbnail.</p>
	<p>Long press-and-hold</p> <p>Use 1 finger and long press-and-hold to drag-and-drop a pattern piece from the tally bar to the workspace.</p>
	<p>Pinch/Stretch</p> <p>Use 2 fingers to zoom in or out of the view in Sewing Instructions. Pinch to decrease the display view and stretch to enlarge the display view.</p>
	<p>Press-and-Move</p> <p>Use 1 finger to move a pattern piece on the workspace. Press-and-hold and move your finger to a different position on the screen.</p>
	<p>Swipe</p> <p>Touch, move and release your finger in a swift gesture to swipe.</p>

	<p>Rotate</p> <p>Use 2 fingers to rotate a pattern piece within the workspace. Press-and-hold both fingers while rotating one finger around the other. Release the pattern piece once the desired rotation is achieved. Note that the pattern piece cannot extend beyond the workspace boundary and will snap to the nearest 45° position.</p>
--	---

How To Connect the Ditto System

- Make sure to enable Bluetooth® and Wi-Fi on your mobile device.
- Connect the Ditto app to the projector through the Ditto app and not within device settings on your mobile device.
- Use the main Wi-Fi in your home for optimal use. Do not use a guest Wi-Fi. Guest Wi-Fi settings may prevent device connection.
- There are two ways to connect the Ditto System – through the app Settings (see “Home screen” below) or the Workspace.

Home screen

1. Go to the Ditto app home screen.
2. Press the menu icon in the top right corner.
3. Select “Settings”. 
4. Select “Manage Projector” in the drop-down menu. 
5. Search for projectors.
6. Allow Ditto Patterns to find, connect and determine the location of nearby devices.
7. Select the projector from the list.
8. Enter Wi-Fi password.
9. Click “Connect to Wi-Fi”.

Note! Make sure to use the same network as connected to your mobile device with the Ditto app installed.

Note! When the Ditto system is properly connected, the projection will change from “Waiting to Connect” to “Connected” under the Ditto logo.

Note! You can also connect the Ditto system by selecting “Connect”  in the Workspace in the Ditto app.

Workspace

1. Click on the "Connect" button  in the workspace.
2. Allow Ditto Patterns to find, connect and determine the location of nearby devices.
3. Select Bluetooth device, "Ditto".
4. Select your network and enter the Wi-Fi password.

Note! Select the same network as connected to your mobile device with the Ditto app installed.

5. Click "Ok".

When the Ditto system is properly connected the Connect button in the workspace will be replaced with a Calibrate button. The projection will change from "Waiting to Connect" to "Connected" under the Ditto logo.

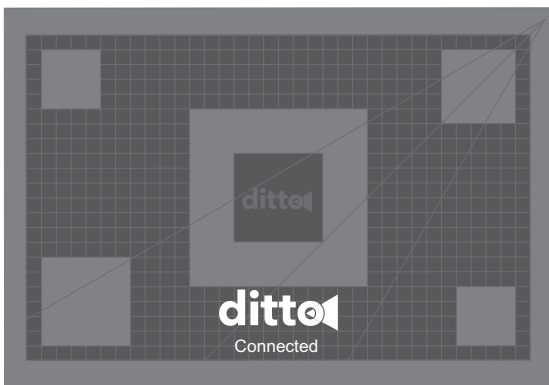

Reconnect Wi-Fi Connection

If the Ditto system loses Wi-Fi connection, a message will appear on the screen and the projection will change to "Waiting to Connect". Reconnect the Ditto system according to the instructions. Refer to "To Connect the Ditto System" on page 11.

To Calibrate the Ditto System

Calibration is the process to remove distortion or skew for an accurate projection. You need to calibrate the Ditto system every time the product has been moved or taken down, if the beam is accidentally knocked out of place, or a different mobile device is used for the Ditto app.

Note! Make sure that the cutting mat is clean and free from markings, target stickers and loose items.

1. Have your room dimly lit.
2. Confirm that the Ditto system is connected to Wi-Fi.
3. Click on the "Calibrate" button in the workspace. 
4. Select "Continue".

Note! Make sure to allow camera access within the app.

5. Follow the instructions in the app to confirm accurate setup and projector height by aligning the red rectangle on top of the white outline.
6. Stand on the opposite side of the projector and follow the instructions in the app to capture a photo when prompted. Make sure to include all 4 corners of the cutting mat.

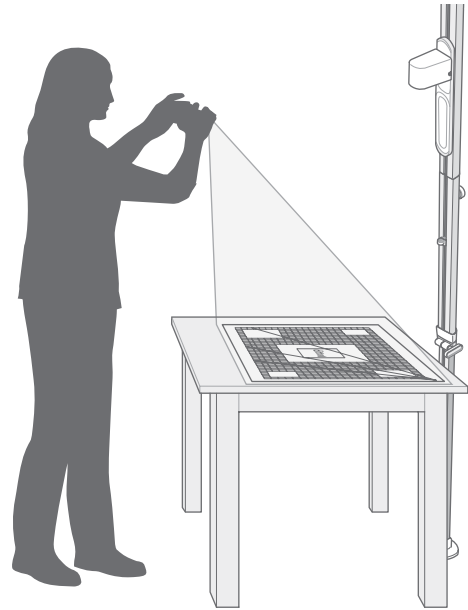

⚠ Warning! Always stand on the floor when you take a picture of the cutting mat. There is a risk of falling if you stand on a chair, a table or similar. Allow enough room to stand back away from table or take the photo from a high angle.

7. Select "Yes" when asked if the photograph is ready to submit. The image usually takes a few seconds to process.
8. The Ditto app will indicate if calibration is successful or not.

Note! If the calibration fails, select one of the following options:

- *Tutorial – To view a video tutorial of the calibration.*
- *Retry – Refer to steps 5-7 in "To Calibrate the Ditto System"*
- *Skip calibration – If you have already calibrated the system and have not moved the beam.*

To Select a Pattern Piece

You can select a pattern from your pattern library or download new patterns from DittoPatterns.com website. The pattern pieces are shown in the scroll bar in the workspace.

1. Tap to select one of your downloaded patterns in "Pattern Library" to open the "Pattern Details".
2. In "Pattern Details" select "Workspace".
3. Please wait while the pattern is being processed by the Ditto system. This can take a few minutes.
4. Access patterns pieces for different types of materials by selecting "Garment", "Lining" or "Interfacing". Depending on whichever you select, the pattern pieces will update in the Pattern Pieces scroll bar at the right.
5. To select your pattern piece, long press-and-hold and then drag-and-drop the pattern piece to the workspace.

Note! Double tap to enlarge a pattern piece on your workspace.

Note! Patterns that are too large for the cutting area are shown with arrows indicating the direction of splicing.

Note! You can position multiple non-spliced pattern pieces in the workspace at the same time.

6. Use 1 finger and Press-and-Move to move a pattern piece in the workspace.
7. Use 2 fingers to rotate a pattern piece in the workspace.
8. Fill the workspace with pattern pieces.
9. Press the checkbox next to the pattern piece to keep track of which pieces have been cut.

Note! Select the "Reset" button if you want to deselect all checkboxes. 

10. If the system has been connected and calibrated the "Send to Projector" button will be red. Select "Send to Projector". Please wait as this may take a few seconds to project your workspace.

Note! You can exit the workspace at any time and your project will be saved for later.

To Remove a Pattern Piece or Pattern Pieces from the Workspace

1. Press on a pattern piece on your workspace to select a pattern piece. The selected pattern piece will highlight in red.

Note! You can select multiple pattern pieces at the same time. You can also click on a pattern piece and select "Select all" if you want to select all pattern pieces on the workspace. 

2. Select "Clear" to remove selected pattern piece(s) from the workspace. 

To Project the Pattern

When you have completed a layout in the workspace, and the system is calibrated, you are ready to send the pattern pieces to the projector.

1. Lay the fabric on the cutting mat.
2. Make sure that the fabric is flat and smooth.
3. Put the weights in the corners of the fabric to prevent the fabric from moving around on the cutting mat.

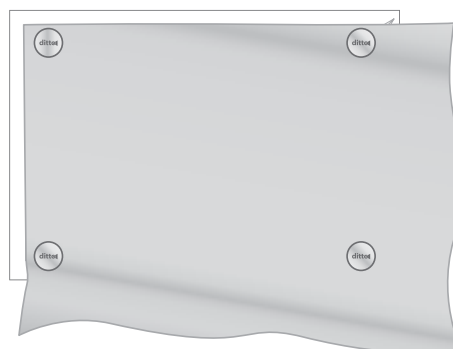

Note! Make sure that the fabric is not hanging off the side of the table. A heavy fabric will pull and wrinkle the fabric resulting in a distorted projection.

4. Press the red "Send to Projector" button.
5. Use a temporary fabric marker to transfer any markings from the pattern to the fabric.

Tip: For a cut on fold piece, you can mirror the projected pattern piece and trace notations onto the opposite side of the fabric.

Tip: Projected words can be difficult to read. Double tap on the pattern piece in the workspace app to zoom in/out to read pattern details on your mobile device.

6. Use the rotary cutter or a pair of scissors to cut the fabric.

To Splice a Pattern Piece

If you have a pattern piece that is too large for the cutting mat, the pattern piece will need to be projected as multiple frames. This is called "Splicing".

Note! A spliced piece cannot be mirrored.

Note! No other pattern pieces can be in the workspace at the same time as a spliced pattern piece.

The spliced pattern pieces in the Ditto app are marked with a red arrow that indicates the direction of the splicing. The direction of the splicing can be vertically, horizontally or in multiple directions

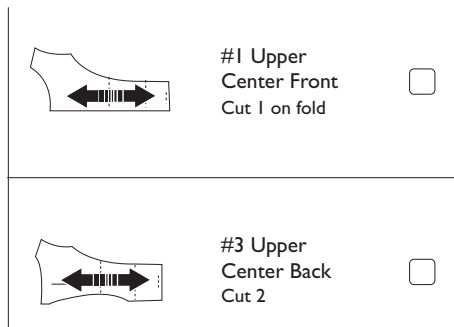

Note! When a large amount of fabric is needed, make sure to fold the excess fabric on the table or drape it onto a chair. If the fabric is draping over the edge of the table the weight of the excess fabric can pull the complete fabric piece down.

Note! Always use fabric weights when splicing a pattern piece to hold the fabric in place.

1. Add a pattern piece. Refer to steps 1-5 "To Select a Pattern Piece" on page 13.
2. Press "Send to projector" to project the pattern pieces. Refer to steps 1-4 in "To Project the Pattern" on page 13.

Note! Red arrows will appear on the spliced pattern piece in the workspace to indicate direction of the splicing. Make sure that there is enough fabric beyond the arrows to account for the entire pattern piece.

3. Mark the projected red splice targets with the provided target stickers. Do not remove the target stickers until the entire pattern piece has been traced.

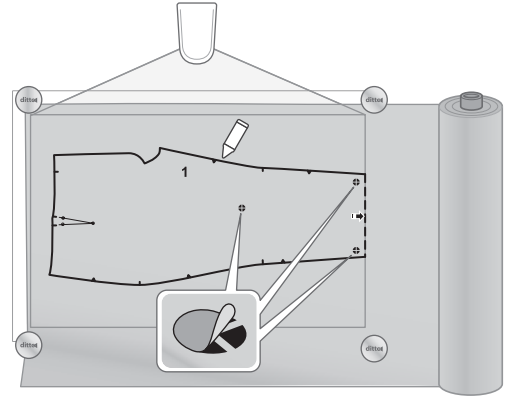

Note! The reference layout shows the splicing map and which frame is being projected.

4. Use a temporary fabric marker to transfer any markings from the pattern to the fabric.
5. Use the rotary cutter or a pair of scissors to cut the fabric.

Note! If you are doing a multi-directional spliced piece, we recommend that you trace the entire projected piece before cutting your fabric.

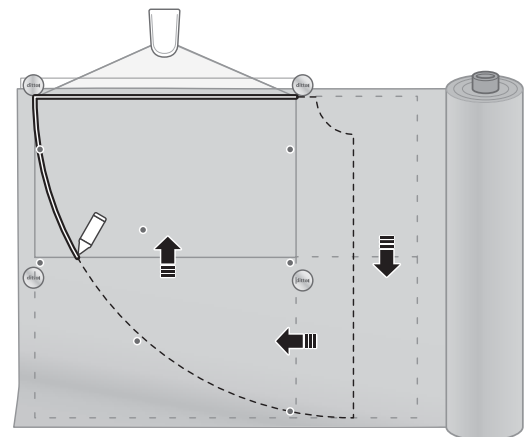

6. When the first part of the pattern piece is cut or traced, tap the red arrows in the workspace to move the pattern piece to the next frame.

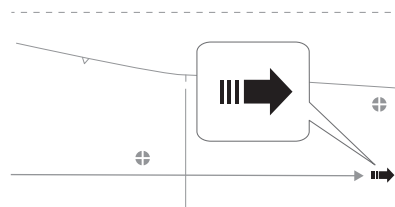

7. Send the pattern to the projector.
8. Follow the arrow directions to reposition the fabric.

- Align pattern lines and target stickers with new projected targets.

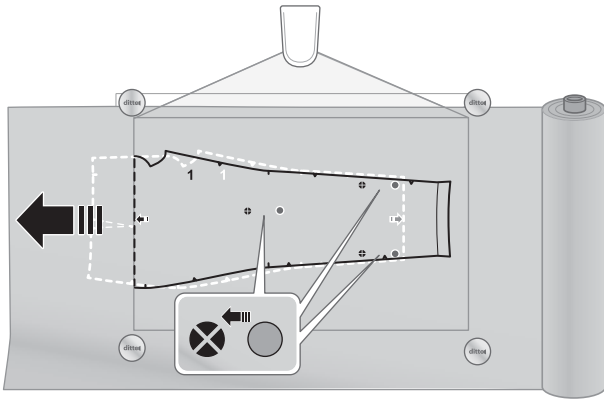



Note! The right scroll bar shows a Splicing Map of the pattern that indicates which splice frame is being projected.

To Mirror a Pattern

Mirroring is the same as flipping the pattern.

Note! Spliced pattern pieces cannot be mirrored

- Select your pattern piece and drag-and-drop the pattern piece to the workspace.
- Tap the pattern piece on your workspace that you want to mirror.
- Select "Mirror vertical" to flip the pattern piece vertically. 
- Select "Mirror horizontal" to flip the pattern piece horizontally. 
- Select "OK".

To Convert a Cut-on-fold Pattern Piece

A sewing pattern that has two symmetrical sides can be cut on the fold of your fabric. The Ditto app enables you to convert a cut-on-fold pattern piece to a pattern for unfolded fabric.

- Select your pattern piece and drag-and-drop the pattern piece to the workspace twice.
- Mirror one piece across the fold line. Refer to "To Mirror a Pattern" on page 15.
- Use 1 finger and Press-and-Move to join the pattern pieces together along the fold line.

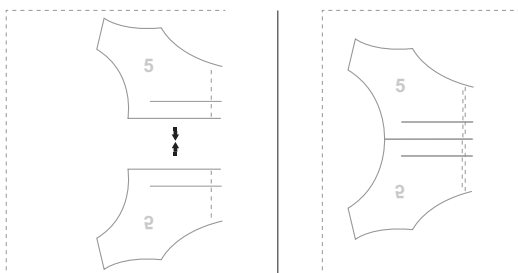

Note! Do not cut the center fold line when cutting.

DISASSEMBLY

- Disconnect the power plug from the power source.
- Slide the projector cart down the beam to eye level.

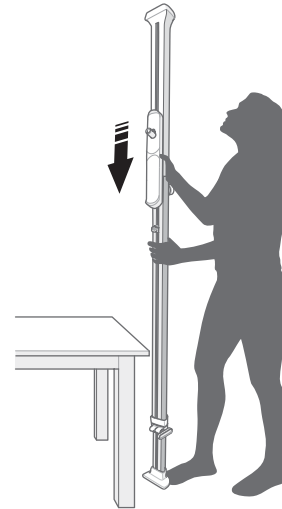

- Remove the cord covers.
- Disconnect the power plug from the projector.
- Make sure that the projector is not covering the joint of the beam.
- Turn the projector 180 degrees clockwise so the lens is facing the ceiling pad.
- Remove the projector and place it on a flat surface out of the way.
- Press down on the beam to depress the spring loaded foot and tilt the beam to the side.
- Put the beam on a table or on the floor
- Loosen the base knob.
- Slide the telescoping piece into the lower beam
- Tighten the base knob.
- Push and turn to loosen the center knob until it pops up and turns freely. Note that the knob remains connected to the beam.
- Pull the two beam sections apart.

MAINTENANCE

⚠ Warning! Read and understand the safety chapter before you do maintenance on the product.

⚠ Warning! Disconnect the power plug from the power source before you do maintenance.

To Clean the Product

- Clean product with a clean and dry cloth.
- Clean the air vents with a brush. Make sure that the air vents are not blocked.

⚠ Caution! Do not use water to clean the product. Water can enter the product and cause short circuit or damage to the product.

To Examine the Product for Damage

- Examine that the cord is not damaged.
- Examine the connections between the projector and the adapter. Also examine the connection between the adapter and the power outlet.

To Store the Product

- Before storage, let the projector cool completely.
- Disconnect the adapter from the projector during storage.
- Attach the cord covers to the beam during storage.
- Preferably store the product in mounted position set up at the work area. Alternatively store the product leaning against the wall in a storage area with the projector detached.
 - The telescoping section can be locked in compressed position, if needed.
- Store the product indoors and at room temperature.

TROUBLESHOOTING AND FAQ

Troubleshooting

General problem	Solution
Setup	
You are not able to set up the Ditto beam.	Make sure you fulfill all the setup requirements. Refer to "To Prepare the Work Area" on page 5.
You don't have a table for use with the system.	Set up the beam in an empty uncarpeted space. Place the cutting mat on the floor next to the beam and project onto the cutting mat using the floor as the cutting surface.
Projection	
The projected image is fuzzy and difficult to read.	The projector must be at the correct height in order to achieve the pre-focused setting. Refer to "Set up" on page 5.
	If the projected lines are extremely blurry after successful setup, the projector could be faulty. Please contact customer service.
You cannot see the projected pattern because of shadows blocking the view.	Move to the other side of the table and use a temporary marker to trace difficult sections to cut later.
Connection	
You cannot connect the Ditto system.	Make sure that the Bluetooth® and Wi-Fi are enabled on your mobile device.
	Make sure that the mobile device is in close proximity to the projector.
	Connect the Ditto app to the projector through the Ditto app and not within device settings on your mobile device. Refer to "To Connect to Ditto App" on page 7.
	Use the main Wi-Fi in your home for optimal use. Do not use a guest Wi-Fi. Guest Wi-Fi settings may prevent device connection.

	Make sure to use the Ditto system in a room with best possible Wi-Fi signal.
The Wi-Fi connection is lost.	Move your work area to a room with good Wi-Fi coverage and connect the Ditto system again. Refer to "To Connect to Ditto App" on page 7.
Workspace	
	Make sure that the system is connected to your Wi-Fi.
The send to projector button isn't active in the workspace of the app.	Make sure that the system has been calibrated and confirm calibration. Note! The setup button will turn red (active) when you confirm the calibration.
Calibration	
You cannot capture an accurate photo for the calibration.	Setup the mat on the short end of a long table or consider positioning the cutting mat on the floor.
	Have your room dimly lit and close window blinds or curtains. Make sure that the overhead lighting is turned off. Tip: If the room lighting cannot be adjusted due to window brightness, consider working later in the day.
The work environment is too bright.	Turn off overhead lights. Tip: Turns lights off for calibration success and turn lights back on, if needed, during pattern piece projection and cutting.
The work environment is creating a bright spot on the cutting mat.	Turn off overhead lights or move anything in the work environment if casting shadows onto cutting mat.
Shadows are cast over top of the cutting mat.	

The calibration photo was taken incorrectly.

Make sure that the full cutting mat, with the calibration projection over top, is captured in the photograph before submitting.

Make sure that the cutting mat fills the majority of the photograph space.

Make sure that the photograph is taken from a top view. Stand on the opposite side of the projector, close to the center of the cutting mat and take a photograph from a high angle. Preferably hold the mobile device at eye level.

⚠ Warning! *Always stay on the floor when you take a picture of the cutting mat. There is a risk of falling if you stand on a chair, a table or similar.*

Make sure to setup the system with enough room on the side of the table opposite the beam. This enables you to stand back away from table, to capture a correct photograph for the calibration of the system.

Always capture the photo in the landscape orientation.

If the projected calibration image is significantly blurred, confirm that the device is held still during photo capture. Confirm the device lens is clean and free of smudges.

Improper setup.

The cutting mat must be positioned accurately with the logo legible from the opposite side of the beam. The mat must be fully on the table and free of objects or markings.

Confirm that the red setup image is accurately placed overtop of the white region on the cutting mat.

The projector must be accurately setup to enable optimized factory focus setting.

If calibration repeatedly fails, and setup is confirmed to be accurate, and the projection still seems blurry, then the system could be faulty. Please contact customer service.

If calibration repeatedly fails, please contact customer service.

Frequently Asked Questions

Question	Answer
Can I set up on a drop ceiling?	Yes. Carefully put the beam on the cross section of the ceiling framework.
Can I set up the beam on ceilings higher than 10 ft. (304 cm)?	No. The beam is only suitable ceiling heights of 7.5 ft. to 10 ft. (228 to 304 cm).
Can I set up the beam to project onto the floor?	Yes. Install the beam into place between floor & ceiling and lower the projector and projector carrier to about 50 in. (127 cm) from the floor surface.
Will I lose work in progress when I close a pattern?	No. The workspace is automatically saved when you exit the Ditto app.
I don't want to continue receiving all the pop-up notifications in the Ditto app. Can I turn them off?	Yes. Turn off notifications in Settings on the Ditto app. Settings is located in menu bar at the top right corner on the home screen.
What if I'm having trouble reading the words and marks on my projected pattern?	Double tap the pattern piece in the workspace to bring a pop-up zoom of the piece. Use two fingers to zoom in and out. You can also put a piece of paper under the project image to see the markings more clearly.
When do I need to calibrate?	Every time the system is moved or the beam is accidentally knocked out of place, or a different mobile device is used to project patterns.
What do I do if my app shows calibration success, but the projected image looks odd/off?	Select the calibrate button again and redo the calibration process.
Are the seam allowances included in the pattern pieces?	Yes. All seam allowances are included in the projection line. Seam allowance amount can be found in the sewing instructions.
My lighting is off, what is the best way to fix this?	Calibration works best in a dimly lit room. You may need to cover any windows and dim the lights.
Where on the projection line should I cut my fabric?	Cut in the middle of the projection line.
Do I need a rotary cutter to use this system?	No. You can cut the projection with a pair of scissors or trace with a marking tool and then cut with a pair of scissors.
How do I determine the size of fabric needed for a spliced piece?	1) Lay out fabric. 2) Project the spliced pattern piece and measure the first part of the spliced pattern piece. 3) Mark the location of the splice target projections with the target stickers. 4) Move projection and fabric to the other end of the spliced pattern piece. 5) Measure from your marked targets to the other end of the projection.
Can I use another cutting mat with this system?	It is not recommended. The included cutting mat is formatted specifically for the calibration of the Ditto system to ensure exact pattern positioning and measurements. ⚠ Caution! Do not to use the Ditto system cutting mat for other crafts, as glue & paint will show up on your picture and could alter your pattern marks.
What if I'm using a very thick fabric like Sherpa, faux fur or heavy fleece?	When calibrating the projector, put the cutting mat on top of the fabric. This enables the projector to calibrate the system based on the thickness of the fabric. When the system is calibrated, put the cutting mat back under the fabric. Trace or cut the fabric on the wrong side of the fabric. Calibrate the projector again before tracing or cutting additional fabrics of standard thickness.
Do I need to trace my pattern, or can I just cut it by following the projection?	You can cut the fabric by following the projected pattern piece lines. But we do recommend that you trace the pattern pieces when there is a multi-directional splice required.

CERTIFICATION REQUIREMENTS

Federal Communication Commission Interference Statement

For the US and Canada

Responsible party: Singer Sourcing Limited LLC
1714 Heil Quaker Boulevard,
Suite 130, LaVergne, TN
37086

Product name: Singer® **Ditto™**

This device complies with Part 15 of the FCC Rules. Operation is subject to the following two conditions: (1) This device may not cause harmful interference, and (2) this device must accept any interference received, including interference that may cause undesired operation.

This equipment has been tested and found to comply with the limits for a Class B digital device, pursuant to part 15 of the FCC Rules. These limits are designed to provide reasonable protection against harmful interference in a residential installation. This equipment generates, uses and can radiate radio frequency energy, and if not installed and used in accordance with the instructions, may cause harmful interference to radio communications. However, there is no guarantee that interference will not occur in a particular installation. If this equipment does cause harmful interference to radio or television reception, which can be determined by turning the equipment off and on, the user is encouraged to try to correct the interference by one or more of the following measures:

- Reorient or relocate the receiving antenna.
- Increase the separation between the equipment and receiver.
- Connect the equipment into an outlet on a circuit different from that to which the receiver is connected.
- Consult the dealer for help.

We reserve the right to change the system equipment and the assortment of accessories without prior notice, or make modifications to the performance or design. Such modifications, however, will always be to the benefit of the user and the product.

INTELLECTUAL PROPERTY

Singer, and the Cameo "S" Design, are exclusive trademarks of The Singer Company Limited S.à.r.l. or its Affiliates.

The Bluetooth® word mark and logos are registered trademarks owned by Bluetooth SIG, inc. and any use of such marks by Singer is under license.

PATENTS AND PATENT APPLICATIONS

Ditto systems and applications are protected by one or more of the patents and patent applications listed at: www.dittopatterns.com/patents

WARRANTY

Warranty terms and conditions can be found online at: warranty.singer.com

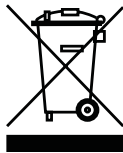

Please note that on disposal, this product must be safely recycled in accordance with relevant National legislation relating to electrical/electronic products. Do not dispose of electrical appliances as unsorted municipal waste, use separate collection facilities. Contact your local government for information regarding the collection systems available. When replacing old appliances with new ones, the retailer may be legally obligated to take back your old appliance for disposal free of charge.

If electrical appliances are disposed of in landfills or dumps, hazardous substances can leak into the groundwater and get into the food chain, damaging your health and well-being.

MANUFACTURER

Newco Jodito LLC
c/o CT Corp.
1209 Orange Street
Wilmington, DE 19801



www.DittoPatterns.com

English • ©2022 The Singer Company Limited S.à.r.l. or its Affiliates. • All rights reserved • Printed on environment friendly paper

Permission is hereby granted to the licensee of the software to which this guide is related to reproduce and distribute copies of this guide for nonprofit educational purposes.
The copyright statement on this page must be included on any copy of this work.